

# **19th World Congress of Soil Science**

## **Symposium 3.3.2**

### **Molecular biology and optimizing crop nutrition**

**Soil Solutions for a Changing World,**

**Brisbane, Australia**

**1 – 6 August 2010**

## Table of Contents

	<b>Page</b>
Table of Contents	ii
1 Ability of nitrogen and phosphorus assimilation of seven strawberry cultivars in a northern Atlantic coastal soil	1
2 Can aluminium resistance and nitrogen utilization of rice be enhanced simultaneously in acidic soils?	5
3 Characterization of selected Kenyan acid soils	9
4 Development and essential oil yield and composition of mint chemotypes under nitrogen fertilization and radiation levels	13
5 Effect of different genotypes of flue-cured tobaccos and different culture methods on k nutrition in rhizospheric and non-rhizospheric soils	16
6 Genotypic variation in micronutrient and cadmium concentrations in grains of 35 upland rice cultivars	20
7 Long-term fertilization effects on grain yield and soil fertility in the paddy soil of Yangtse Delta in China	23
8 Optimisation of nutrient transport processes by plants -boron transport as an example	26

# Ability of nitrogen and phosphorus assimilation of seven strawberry cultivars in a northern Atlantic coastal soil

Hong Li<sup>A</sup>, Ruiping Huang<sup>A</sup>, Tingxian Li<sup>B</sup> and Kelin Hu<sup>C</sup>

<sup>A</sup>Nova Scotia Agricultural College, Department of Plant and Animal Sciences, Truro, Nova Scotia, B2N 5E3 Canada. hli@nsac.ca

<sup>B</sup>Ministry of Sustainable Development, Environment and Parks of Quebec, Sustainable Development and Ecological Inheritance Services, Quebec City, Quebec, G1R 5V7 Canada. Tingxian.li@mddep.gouv.qc.ca

<sup>C</sup>China Agricultural University, Department of Soil and Water Sciences, Beijing 100094, China.

## Abstract

Optimizing plant nitrogen (N) and phosphorus (P) nutrition is required in healthy propagation of strawberry nursery plants for fruit production. Strawberry (*Fragaria x ananassa* Duch.) nursery plant ability for N and P acquisition was examined in a northern Atlantic coastal soil for providing field-based information for optimizing strawberry nursery plant nutrition. The study was conducted in a Cornwallis loamy soil in Nova Scotia, Canada in 2008. The treatments consisted of seven strawberry cultivars: 'Darselect', 'Mesabi', 'V151', 'Seneca', 'Serenity', 'K93-20' and 'Jewel', all highly hardy cultivars. Nutrient NPK supply was respectively at the rates of 105, 145 and 165 kg/ha, based on soil testing and regional recommendation. Results showed that strawberry nursery plant propagation and productivity expressed using runner and daughter-plant variables were significantly different among the seven cultivars ( $P < 0.05$ ). Total nitrogen uptake (mean±SD) varied between 2.96±0.91 g/plant and total P uptake was 0.29±0.06 g/plant among the seven cultivars. The cultivar 'Seneca' and 'Jewel' showed a significantly higher ability of N and P acquisition ( $P < 0.05$ ). However, only higher N and P acquisition in 'Seneca' was corresponding to significantly higher runner numbers (23 runners/mother-plant) and daughter plants (42 daughters/mother-plant). Significantly lower productivity was associated with lower N and P uptake in the cultivars 'Darselect', 'Mesabi' and 'V151'. Whole plant P accumulation increased with increasing of N accumulation (up to 4.7 g/plant,  $R^2 = 0.76$ ,  $P < 0.01$ ). It was suggested that strawberry nursery plant propagation could be enhanced with nutrition accumulation ranges of 2.47-3.26 g N/plant and 0.25-0.34 g P/plant. Runner thinning would be an option for regulating strawberry plant N and P nutrition and nursery plant productivity.

## Key Words

Plant nitrogen, phosphorus nutrition, plant propagation, strawberry nursery plants.

## Introduction

Northern Atlantic climate (warm summer and cool fall) of Canada is favourable for growing cold-stored, disease-free strawberry (*Fragaria x ananassa* Duch.) nursery plants. Strawberry mother plants are transplanted in early spring for propagating in Nova Scotia and the nursery plants are harvested then shipped to many states for strawberry fruit production across North American. Strawberry plant is a rapid top-growth crop (Li *et al.* 2009a). The growth of crown, leaves, runners and daughter plants can occur in a short time (e.g. 2-3 months), depending on nutrient, light, temperature, salinity or water conditions (Kenlgen and Pawelzik 2009; Li *et al.* 2010). It is reported that strawberry plants require a high acquisition of N and P nutrition for the need of photosynthesis and rapid top growth (Li *et al.* 2009a). Nitrogen (N) is recognized as the most limiting nutrient to plant development and N nutrition determines crop yield and quality (Lea and Azevedo 2006; Li *et al.* 2006), and more than 50% of leaf-N is in components associated with plant photosynthesis (Gastal and Lemaire 2002). Phosphorus, an important nutrient for propagation, vigor and general health of all plants, is often referred to as the 'energizer' because it helps store and transfer energy within plants during photosynthesis process (Busman *et al.* 1998; Schachtman 1998).

Knowledge of crop N and P requirements is essential in developing profitable nutrient management planning to meet plant needs for producing high quality crops (Gastal and Lemaire 2002; Li *et al.* 2006; 2009a). Selecting cultivars efficient in nutrient use could be an option for producing high quality crops (Li *et al.* 2009b). The objectives of this study were to understand the N and P acquisition ability of seven strawberry cultivars and to examine the co-limitation of N and P nutrition in strawberry plant nursery propagation.

## Methods

### *Filed experimental treatments*

The study was conducted in a deep, moderately-drained Cornwallis sandy loam in Annapolis Valley, Nova Scotia. The soil was classified as an Orthic Humo-Ferric Podzol. The soil was acidic, pH (soil:water/1:1) 5.9 and had a medium soil fertility level (P, K, Ca, Mg and Fe concentrations at 69, 98, 1,858, 247 and 32 mg/kg, respectively). The previous crop was a 2-year perennial ryegrass (*Lolium perenne* L.) that was chemically killed and incorporated into the soil in the spring.

The experimental treatments consisted of seven strawberry cultivars: 'Darselect', 'Mesabi', 'V151', 'Seneca', 'Serenity', 'K93-20' and 'Jewel', all highly hardy cultivars. The fertilizer NPK was applied at a constant rate of 105 kg N, 145 kg P<sub>2</sub>O<sub>5</sub> and 165 kg K<sub>2</sub>O per ha, based on the soil test performed in the spring and regional recommendations. The NPK fertilizers were split applied with an equal rate at transplanting and at runner stage, using ammonium-nitrate (NH<sub>4</sub>NO<sub>3</sub>, 27.5-0-0), monocalcium phosphate Ca(PO<sub>4</sub>)<sub>2</sub> (0-46-0) and potassium chloride (KCl, 0-0-60).

The strawberry mother plants were transplanted in strip in the field in early May 2008. The spacing was 1.5 m between rows and 0.25 m apart between plants on the row. Irrigation was done on a rainfall compensation basis using sprinkler system with pipes installed 24 m apart across the field. The strawberry nursery plants were maintained using regional recommendations of insecticides, fungicides and herbicides. Flowering stems on the plants were consistently removed as they appeared. The flower thinning strengthened the mother plants and runner plants.

### *Strawberry plant propagation and N and P acquisition measurements*

During the growing season, we assessed the strawberry plant propagation status at runner development stage, daughter plant growth stage and at harvest (2 well-rooting daughter plants per early runner). Strawberry whole plants including roots, runners, daughter plants and leaves were sampled individually at 10 geo-referenced points (Garmin International, Olathe, KS) in a 15 x 5 sampling grid for each cultivar. Strawberry plant heights, total leaves, runners, runner tip lengths, daughter plants, root length, leaf spots, biomass, dry matters, spot leaves and dead runner of whole plant samples were determined in the laboratory. Soil samples (0-0.15 m) were taken simultaneously at each geo-referenced point at each plant sampling time. Gravimetric soil water content and soil pH (1:1 soil/water) were determined for each sample.

Strawberry whole plant tissues were ground into 0.5-mm size and concentrated H<sub>2</sub>SO<sub>4</sub> solution and 30% H<sub>2</sub>O<sub>2</sub> solution were used for plant tissue digestion. Plant total N was analysed using Kjeldahl steam distillation analysis (Labconco, Kansas City, MO). Plant total P was determined using Libra spectrophotometer (Biochrom, Cambridge, UK) using ascorbic method by reading at 880 nm (Jones 2001).

Descriptive statistics, correlation and regression analysis of plant and soil data were done using PROC UNIVARIATE, PROC CORR and PROC GLM (SAS Institute 1990). Homogeneity of datasets was verified using the Bartlett test, normality and residual distribution of data sets were confirmed using PROC UNIVARIATE, and comparison of the means was done using the Honestly Significant Difference (HSD) test (SAS Institute 1990).

## Results

There was a significant difference in strawberry nursery plant development among the seven cultivars, V1='Darselect', V2='Mesabi', V3='V151', V4='Seneca', V5='Serenity', V6='K93-20' and V7='Jewel', in this Cornwallis loam (Figure 1). The highest nursery productivity expressed in well-rooting daughter plants was 42 daughters, determined in the cultivar 'Seneca'. The highest runner number was 25 runners per mother plant, measured in the cultivar 'K93-20' (Figure 1). The optimum daughter/runner ratio was 1.7-1.8, determined in the cultivars 'Seneca' and 'Serenity', which had the significant higher runners and daughter plants than the other varieties ( $P < 0.05$ ). The cultivar 'Mesabi' had the significantly higher spot leaves (8 tri-leaves per mother plant) and dead runners (4 dead runner/mother plants) than the other cultivars, which might be the reason for its lowest daughter plant numbers (Figure 1).

Total plant N uptake varied between 1.66-3.63 g/plant and the mean and standard deviation (SD) were  $2.96 \pm 0.91$  g/plant (or  $78.9 \pm 5.9$  kg/ha). The cultivars 'Serenity' and 'Jewel' had the highest N uptake ability among the seven cultivars (Figure 2). Total P uptake ranged between 0.17-0.42 g/plant with a mean and SE

value of  $0.29 \pm 0.06$  g/plant (or  $7.73 \pm 0.26$  kg/ha) among the seven cultivars. The cultivar ‘Serenity’ and ‘Jewel’ showed a significantly higher ability of P acquisition than other cultivars (Figure 2). The significantly lower nursery productivity was associated with lower N/P uptake in the cultivars ‘Darselect’, ‘Mesabi’ and ‘V151’ (Figure 1-2).

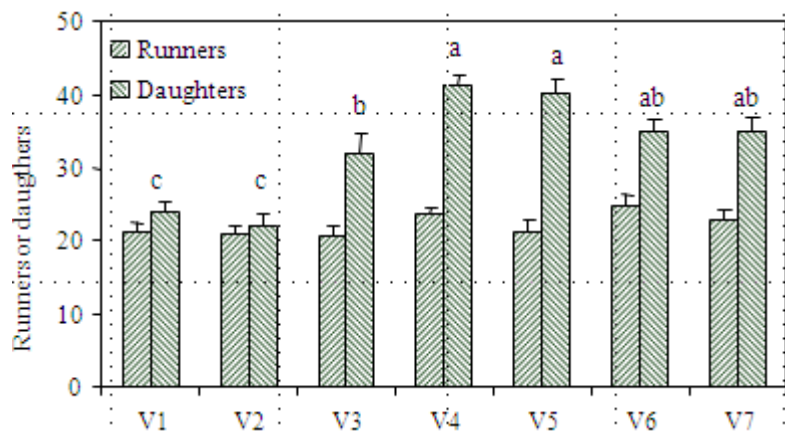
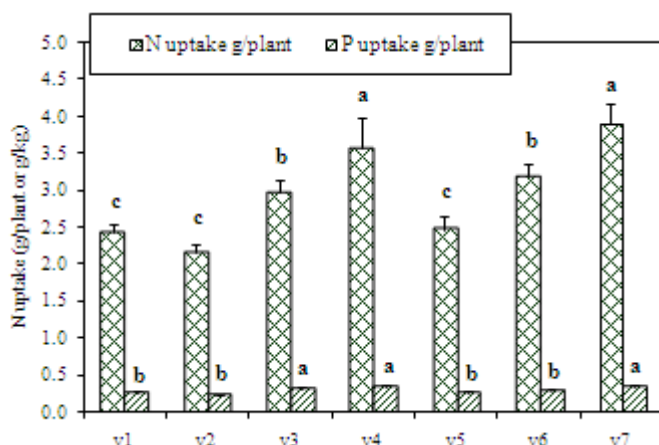

**Figure 1.** The productivity of strawberry nursery plants expressed as living runners and daughter plants. There were: V1=‘Darselect’, V2=‘Mesabi’, V3=‘V151’, V4=‘Seneca’, V5=‘Serenity’, V6=‘K93-20’ and V7=‘Jewel’. Each bar was the mean and SE value of 30 measurements. The means with the same letter was not significantly different at the probability  $P < 5\%$ .

The significantly higher ability of N and P acquisition in the cultivar ‘Serenity’ was corresponding to their significantly higher runner numbers (23 runners/mother plant) and daughter plants (42 daughters/mother plant). For the cultivar ‘Jewel’, the higher N and P uptake did not enhance plant propagation (low daughter plant numbers).

Whole plant P accumulation increased with increasing of N accumulation (up to 4.7 g/plant). The plant P accumulation ( $P_{\text{accu}}$ ) and plant N accumulation ( $N_{\text{accu}}$ ) can be described by the quadratic equation as follows:  $P_{\text{accu}} \text{ (g/plant)} = -0.0745 + 0.1808N_{\text{accu}} - 0.0181N_{\text{accu}}^2$  ( $R^2 = 0.76$ ,  $P < 0.01$ ,  $n = 70$ ).

Significantly higher strawberry runner and well-rooting daughter plants were in the nutrition accumulation ranges of 2.47-3.26 g N/plant and 0.25-0.34 g P/plant. Further determination of effects of runner thinning on plant N and P acquisition ability might possibly help understand if thinning can help regulate strawberry plant N and P uptake and nursery propagation.



**Figure 2.** The ability of N and P acquisition of seven strawberry cultivars measured at harvest. There were: V1=‘Darselect’, V2=‘Mesabi’, V3=‘V151’, V4=‘Seneca’, V5=‘Serenity’, V6=‘K93-20’ and V7=‘Jewel’. Each bar was the mean and SE value of 10 measurements. The means with the same letter was not significantly different at the probability  $P < 5\%$ .

The data showed also that the runner and daughter numbers of the seven strawberry cultivars were related to soil water content (SWC) and pH values ( $0.63 < R^2 < 0.91$ ). Soil water and pH levels might have also affected strawberry N and P acquisition ability among the different cultivars. The regression relationships of strawberry nursery plant performance and soil water and soil pH were significant, as shown by the equations as follows:

Strawberry variety	Regression equations	$R^2$
V5='Serenity'	Runner = 4.62 SWC – 20.54	0.82**
V7= 'Jewel'	Runner = 4.58 SWC – 19.18	0.81**
V5='Serenity'	Daughter = 11.9 pH – 26.59	0.91**
V7= 'Jewel'	Daughter = 13.4 pH – 40.56	0.89**

## Conclusion

The ability of plant N and P assimilation was significantly different among the seven strawberry cultivars. The cultivar 'Seneca' and 'Jewel' had a significantly higher ability of N and P uptake but only higher N and P acquisition in the cultivar 'Seneca' has related to significantly higher productivity expressed by daughter plant numbers. Significantly lower nursery productivity was associated with lower N and P uptake in the cultivars 'Darselect', 'Mesabi' and 'V151'. Strawberry propagation could be affected by its ability of acquisition of N and P nutrition but other factors such as runner numbers, soil water and soil pH might also influence plant N and P uptake and strawberry development. It is needed to further examine the relationships between strawberry plant N and P acquisition with runner thinning and these soil physical factors for regulating N and P nutrition in strawberry nursery plants.

## References

- Busman L, Lamb J, Randall G, Rehm G Schmitt M (1998) The nature of phosphorus in soils. Document FO-06795-GO, University of Minnesota. Minneapolis, MN.
- Gastal F, Lemaire G (2002) N uptake and distribution in crops: an agronomical and ecophysiological perspective. *Journal of Experimental Botany* **53**, 789-799.
- Jones BJ (2001) Laboratory guide for conducting soil tests and plant analysis. CRC Press, NY. 363 p.
- Keutgen AJ, Pawelzik E (2009) Impacts of NaCl stress on plant growth and mineral nutrient assimilation in two cultivars of strawberry. *Environmental & Experimental Botany* **65**, 170-176.
- Lea PJ, Azevedo RA (2006) Nitrogen use efficiency. I: Uptake of nitrogen from the soil. *Annals of Applied Biology* **149**, 243-247.
- Li H, Parent LE, Karam A (2006) Simulation modeling of soil and plant nitrogen use in a potato cropping system in the humid and cool environment. *Agriculture, Ecosystems & Environment* **115**, 248-260.
- Li H, Li T, Gordon RJ, Asiedu S (2009a) Relationships of strawberry nursery plant propagation with soil phosphorus, iron and water variation. In 'Proc. 16<sup>th</sup> International Plant Nutrition Colloquium. Functions, Interactions and Diagnosis of Nutrient Status'. p. 17-19.
- Li H, Gordon RJ, Lada R, Asiedu S (2009b) Nitrogen assimilation ability of three cauliflower cultivars in relation to reduced post-transplanting nitrogen supply. In 'Proc. 16<sup>th</sup> International Plant Nutrition Colloquium. Nutrient Acquisition, Homeostasis and Sink/Source Relations'. p. 8-13.
- Li H, Li T, Gordon RJ, Asiedu S, Hu K (2010) Strawberry plant fruiting ability and its correlation with solar irradiance, temperature and reflectance water index variation. *Environmental & Experimental Botany* **68**, 165-174.
- SAS Institute (1990) SAS/STAT user's guide. Vol. 2, GLM-VARCOMP. Vers. 6, 4th ed. SAS Institute. Cary, NC.
- Schachtman DP, Reid RJ Ayling SM (1998) Phosphorus uptake by plants: From soil to cell. *Plant Physiology* **116**, 447-458.

# Can aluminium resistance and nitrogen utilization of rice be enhanced simultaneously in acidic soils?

Xue Qiang Zhao and Ren Fang Shen

State Key Laboratory of Soil and Sustainable Agriculture, Institute of Soil Science, Chinese Academy of Sciences, Nanjing 210008, China, Email rfshen@issas.ac.cn

## Abstract

There are many factors limiting plant growth in acidic soils. Aluminium toxicity and ammonium-nitrogen often coexist in acidic soils due to low pH and poor nitrification. Understanding the mechanisms responsible for aluminium-ammonium interaction can help improve agricultural production and maintain ecological stability in acidic soils. The effects of ammonium and nitrate on Al resistance, of aluminium on ammonium uptake, and the correlation between aluminium resistance and nitrogen utilization were investigated here. The results indicated that ammonium enhances aluminium resistance of rice compared with nitrate. Aluminium does not inhibit ammonium uptake of Al-resistant rice cultivar but does that of the Al-sensitive rice cultivar, and Al-resistant rice cultivar exhibits higher ammonium uptake rate under Al stress compared with the Al-sensitive cultivar. Al resistance in rice is positively correlated with ammonium utilization or negatively correlated with nitrate utilization. Based on these results, it is possible to increase aluminium resistance and nitrogen utilization at the same time in acidic soils through the development of Al-resistant and ammonium-preferring rice cultivars and the application of suitable types of nitrogen fertilizers.

## Key Words

Ammonium, nitrate, preference, toxicity, indica, japonica.

## Introduction

Soil acidity is one of the most important limitations to agricultural production worldwide (Kochian *et al.* 2004). Approximately 30% of the world's total land area consists of acidic soils, and as much as 50% of the world's potentially arable lands are acidic (von Uexküll and Mutert 1995). In China, acidic soils cover about 2.18 million km<sup>2</sup>, accounting for 22.7% of the total land (Zhao *et al.* 2002). At soil pH values at or below 5, dissolution of Al-bearing minerals results in toxic aluminium (Al) forms, inhibiting root growth and function, and thus reducing crop yields (Kochian *et al.* 2005). Except for aluminium toxicity, there are several other factors limiting crop production in acidic soils such as proton toxicity, manganese toxicity, and low phosphorus stress, but nitrogen (N) problems are generally not included in these limiting factors.

N is one of plant essential macronutrients and plays an important role in plant growth. If plants grown in acidic soils can not effectively utilize nitrogen, agricultural production and ecological safety of acidic soils can not be guaranteed even if other limiting factors were overcome. In fact, N utilization of plants and N transformation in acidic soils are apparently different from those in neutral to calcareous soils. Ammonium and nitrate are two main inorganic N forms available for plant uptake in soils. In the field, inorganic nitrogen occurs predominantly as NH<sub>4</sub><sup>+</sup> in soils of pH 4.0 to 6.0 and as NO<sub>3</sub><sup>-</sup> in soils of pH 6.0 to 8.0 (McGrath and Rorison 1982). Another critical factor for the survival of plants in acidic soils is the presence of NH<sub>4</sub><sup>+</sup>, which is a predominant N-source, since nitrification is depressed in these soils (Watanabe *et al.* 1998).

Thus, acidic soils may be dominated chemically not only by Al<sup>3+</sup> but also by NH<sub>4</sub><sup>+</sup>, and neutral to calcareous soils, although lacking toxic concentrations of Al<sup>3+</sup>, do have higher concentrations of NO<sub>3</sub><sup>-</sup> (Rorison 1985). Therefore, it is of interest and significance to investigate plant Al resistance and N utilization as a whole.

Rice prefers NH<sub>4</sub><sup>+</sup> as a major inorganic N-source since NH<sub>4</sub><sup>+</sup> is the predominant N species in anaerobic agricultural soils, in particular in paddy fields. In addition, the degree of Al resistance among small cereal crops usually follows the order rice ≥ rye > wheat > barley although genotypic variation also exists in each species (Ma *et al.* 2002). Our previous results have demonstrated that ammonium can alleviate Al toxicity in rice and reduce Al accumulation in roots compared with nitrate (Zhao *et al.* 2009). The present study is to further investigate N-Al interaction and the relationship between Al resistance and N utilization in rice, which are expected to provide experimental evidence for the hypothesis that Al resistance and N utilization of rice can be increased at the same time in acidic soils.

## Methods

### *Plant materials and grown conditions*

Two rice cultivars, indica cultivar kasalath (Al-sensitive) and japonica cultivar koshihikari (Al-resistant) (Ma *et al.* 2002) were used to investigate the effects of N forms on Al resistance and of Al on ammonium uptake. Thirty rice cultivars were used to study the correlation between N utilization and Al resistance. Rice seedlings were cultured in a growth chamber as described previously (Zhao *et al.* 2009). Al,  $\text{NH}_4^+$ , and  $\text{NO}_3^-$  were applied as  $\text{AlCl}_3 \cdot 6\text{H}_2\text{O}$ ,  $\text{NH}_4\text{Cl}$ , and  $\text{NaNO}_3$ , respectively. Each experiment was conducted with three replicates.

### *Effects of ammonium and nitrate on Al resistance*

Ten-day-old seedlings were treated in a full-strength Kimura B nutrient solution (pH 4.5) containing 1mM N as  $\text{NH}_4^+$  or  $\text{NO}_3^-$  without (-Al) or with (+Al) 50  $\mu\text{M}$  Al for 28 days. The pH of the culture solutions was initially adjusted to 4.5 by addition of 0.1 M HCl or NaOH and the solutions were renewed daily.

### *Ammonium uptake*

Twenty eight-day-old seedlings were firstly treated in an N free full-strength Kimura B nutrient solution (pH 4.5) for 24 h, and then in an N free full-strength Kimura B nutrient solution (pH 4.5) without (-Al) or with (+Al) 50  $\mu\text{M}$  Al for another 24 h. The treated rice seedlings (two seedlings each) were placed in a 150-mL black cup containing full-strength Kimura B solution (pH 4.5) of 1 mM  $\text{NH}_4^+$  for 3 h. The initial and final concentrations of  $\text{NH}_4^+$  in solution were determined colorimetrically at 610 nm. Transpiration (water loss) was also recorded. At the end of the experiment, the roots were separated and its dry weight was measured.  $\text{NH}_4^+$  uptake rate was estimated via the depletion of  $\text{NH}_4^+$  in the absorption solution during the experiments.

### *Evaluation of Al resistance and nitrogen utilization*

Relative root dry weight (root dry weight with ammonium / root dry weight with nitrate X 100%) was used to express ammonium utilization ability of rice cultivars. Root dry weights were measured after different rice cultivars were grown in a full-strength Kimura B nutrient solution (pH 4.5) containing 2 mM  $\text{NH}_4^+$  or  $\text{NO}_3^-$  for 24 days. Relative root elongation (root elongation with +Al / root elongation with -Al X 100%) was measured before and after rice seedlings were grown in 0.5 mM  $\text{CaCl}_2$  solution (pH 4.5) without (-Al) or with 50  $\mu\text{M}$  Al (+Al) for 24 h.

## Results

### *Effects of ammonium and nitrate on Al resistance*

After rice seedlings were treated with 50  $\mu\text{M}$  Al in nutrient solutions containing different N forms for 28 days, almost no inhibiting effects of Al on rice growth were observed under ammonium nutrition irrespective of Al-resistant or Al-sensitive cultivar, but huge inhibiting effects of Al on rice growth of two cultivars exhibited under nitrate nutrition (Figure 1).

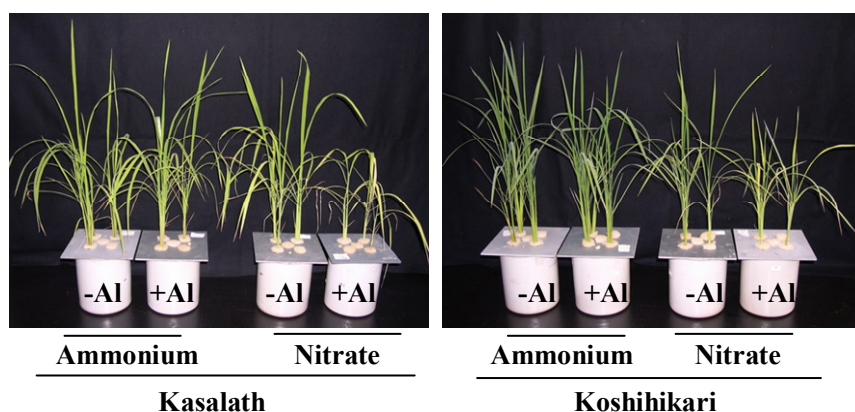

**Figure 1.** The growth appearance of Al-resistant cultivar koshihikari and Al-sensitive cultivar kasalath under Al stress with different nitrogen form supply.

Corresponding with the appearance of rice seedlings (Figure 1), stronger decrease in shoot and root dry weight by Al treatment was found with nitrate than with ammonium (Figure 2). These results further demonstrated that ammonium can alleviate Al toxicity of rice compared with nitrate, which is consistent with our previous reports (Zhao *et al.* 2009).



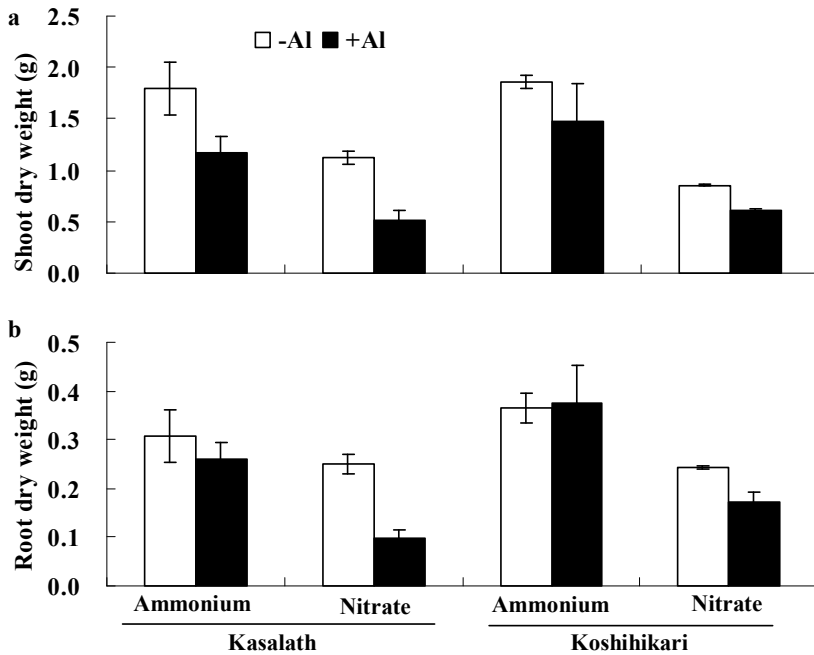

Figure 2. Effects of Al on shoot dry weight (a) and root dry weight (b) of Al-resistant cultivar koshihikari and Al-sensitive cultivar kasalath with different N form supply. Data are means  $\pm$  SD (n = 3).

*Effects of aluminium on ammonium uptake*

Pre-treatment with 50  $\mu$ M Al significantly decreased ammonium uptake of kasalath but not that of koshihikari (Figure 3). When no Al addition, koshihikari showed similar even lower ammonium uptake rate compared with kasalath, but when Al was added, ammonium uptake rate of koshihikari was higher than that of kasalath (Figure 3). These results suggested that Al did not inhibit ammonium uptake of Al-resistant rice cultivar which obtained higher ammonium uptake rate under Al stress.

*Correlated relationship between rice Al resistance and N utilization*

The correlation analyse indicated that there was a positive correlation between Al resistance and ammonium utilization ability in rice (Figure 4). It can be said that: if one rice cultivar can preferentially utilize ammonium over nitrate, it will be more Al-resistant, or, if one rice cultivar can preferentially utilize nitrate over ammonium, it will be more Al-sensitive. The two genetic traits of inorganic N utilization and Al resistance in rice often come along with each other.

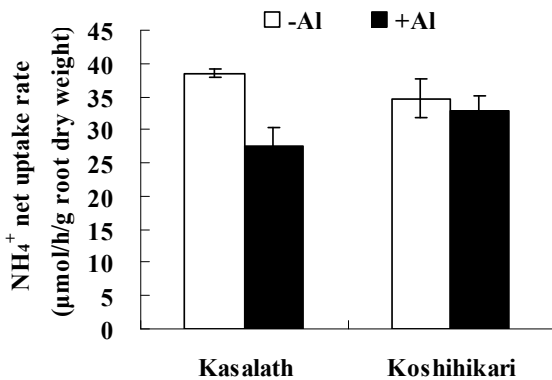

Figure 3. Effects of aluminium on ammonium uptake by Al-resistant cultivar koshihikari and Al-sensitive cultivar kasalath. Data are means  $\pm$  SD (n = 3).

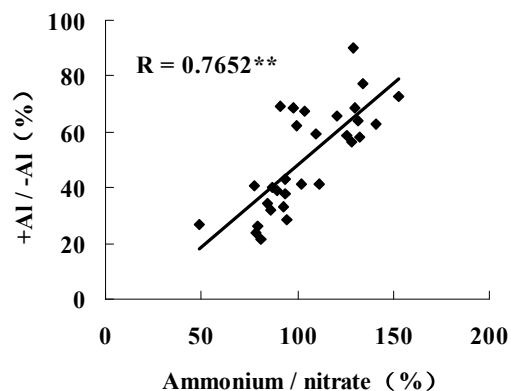

Figure 4. The correlation analyse between Al resistance and N utilization in 30 rice cultivars. +Al / -Al (%) expresses relative root elongation. Ammonium / nitrate (%) expresses relative root weight.

## Conclusion

It can be concluded that: (1) compared with nitrate, ammonium can alleviate Al toxicity or enhance Al resistance of rice; (2) Al does not inhibit ammonium uptake of Al-resistant rice cultivar but does that of Al-sensitive cultivar, and Al-resistant rice cultivar obtains higher ammonium uptake rate under Al stress compared with Al-sensitive cultivar; (3) Al resistance is positively correlated with ammonium utilization. According to these conclusions, we point out that it is possible to enhance Al resistance and N utilization of rice at the same time in acidic soils through the selection of rice cultivars, soil fertilizer management and molecular genetic modification. More experimental evidences of field experiments and molecular biology are needed in future research.

## Acknowledgements

This research was financially supported by the National Natural Science Foundation of China (No. 40871144, 40921061). We thank Prof. Jian Feng Ma (Okayama University) for generous provision of rice materials.

## References

- Kochian LV, Hoekenga OA, Piñeros MA (2004) How do crop plants tolerate acid soils? Mechanisms of aluminum tolerance and phosphorous efficiency. *Annual Review of Plant Biology* **55**, 459-493.
- Kochian LV, Piñeros MA, Hoekenga OA (2005) The physiology, genetics and molecular biology of plant aluminum resistance and toxicity. *Plant and Soil* **274**, 175-195.
- Ma JF, Shen RF, Zhao ZQ, Wissuwa M, Takeuchi Y, Ebitani T, Yano M (2002) Response of rice to Al stress and identification of quantitative trait loci for Al tolerance. *Plant and Cell Physiology* **43**, 652-659.
- McGrath SP, Rorison IH (1982) The influence of nitrogen source on the tolerance of *holcus lanatus* L. and *bromus erectus* huds. to manganese. *New phytologist* **91**, 443-452.
- Rorison IH (1985) Nitrogen Source and the tolerance of *Deschampsia flexuosa*, *Holcus lanatus* and *Bromus erectus* to aluminium during seedling growth. *Journal of Ecology* **73**, 83-90.
- von Uexküll HR, Mutert E (1995) Global extent, development and economic impact of acid soils. *Plant and Soil* **171**, 1-15.
- Watanabe T, Osaki M, Tadano T (1998) Effects of nitrogen source and aluminum on growth of tropical tree seedlings adapted to low pH soils. *Soil Science and Plant Nutrition* **44**, 655-666.
- Zhao QG, et al (2002) 'Red soil material cycle and its regulation'. (Beijing: Science Press) (In Chinese).
- Zhao XQ, Shen RF, Sun QB (2009) Ammonium under solution culture alleviates aluminum toxicity in rice and reduces aluminum accumulation in roots compared with nitrate. *Plant and Soil* **315**, 107-121.

# Characterization of selected Kenyan acid soils

Pamela A. Obura<sup>A</sup>, Darrell G. Schulze<sup>A</sup>, John R. Okalebo<sup>B</sup>, Caleb O. Othieno<sup>B</sup> and Cliff T. Johnston<sup>A</sup>

<sup>A</sup>Department of Agronomy, Purdue University, Lilly Hall of Life Sciences, 915 West State Street, West Lafayette, IN 47907-2054. Email pobura@purdue.edu

<sup>B</sup>Department of Soil Science, Moi University, P.O. Box 1125, Eldoret, Kenya.

## Abstract

Declining soil fertility is a major cause of food insecurity in sub-Saharan Africa. In order to describe Kenyan acid soils, 11 sites were selected, described and sampled. Laboratory analyses conducted included: soil pH, total carbon and nitrogen, loss on ignition, extractable phosphorus, exchangeable bases and Al, cation and anion exchange capacities, and ammonium oxalate and dithionate citrate bicarbonate extractable iron. With a few exceptions, the results indicate the following general trends: low soil pH, low P, low effective cation exchange capacity, and relatively high aluminum saturation. Low plant nutrient reserves, particularly phosphorus, and likely aluminum toxicity seem to be the major limitations for sustainable agricultural use and management of these soils.

## Key Words

Soil acidity, exchangeable bases, aluminum saturation, available phosphorus.

## Introduction

Low crop production in acid soils is usually due to several factors affecting different physiological and biochemical processes, both in the soil and plant (Foy, 1984). Typically, the main constraints in the kaolinite-rich soils common in humid tropical and subtropical climate regions include weak buffering capacity; low P bioavailability due to high P fixation capacity; toxicities of Al, Fe, Mn (occasionally H); deficiencies of Ca, Mg, K, Zn, S, and Mo; and low cation exchange capacity (CEC) (Clark *et al.* 1988). These deficiencies or toxicities often act together to limit plant growth (Clark 1982). This study was undertaken as a part of a larger project whose main objective is to improve the productivity of maize and sorghum grown on acid soils in central Brazil and East Africa. An understanding of the soil chemical context of the root-soil environment, as well as the broader agro-ecological context into which enhanced germplasm is likely to be introduced, is essential. The objective of this study was to obtain baseline information on the soil chemical properties of representative soils in different maize growing regions of Kenya, the target area for eventual introduction of germplasm with enhanced Al-tolerance and P-use efficiency.

## Methods

The exploratory soil map of Kenya (Sombroek *et al.* 1982) was used to identify acid soils in major maize growing areas. Samples were collected from 8 pedons west of the Rift Valley (Kuniet, KN01; Chepkoilel, KN02; Vihiga, KN03; Ikhelomani, KN04; Bumala, KN05; Siaya, KN06; Kisii, KN07; and Kericho, KN08), and 3 pedons east of the Rift Valley (Kangema, KN09; Kerugoya, KN10; and Embu, KN11) (Figure 1).

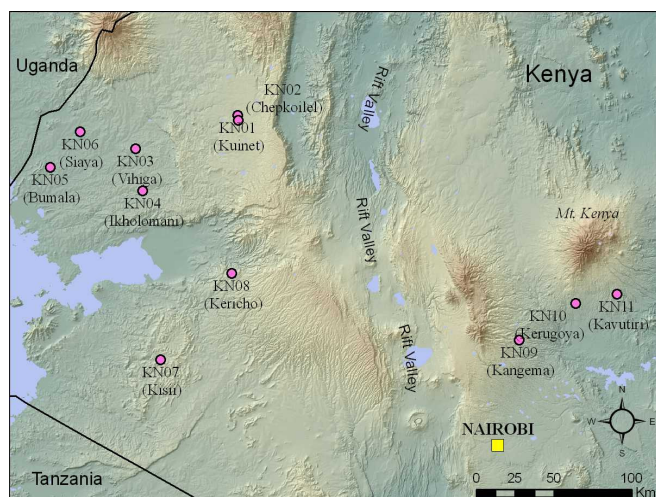

Figure 1. A map of western Kenya showing the sampling locations.

Soil pH was measured using a 1:1 soil: water/solution ratio (Thomas 1996), total carbon (C) and nitrogen (N) was determined using an automatic analyzer (Leco CHN – 2000, LECO Corporation, 3000 Lakeview Avenue, St. Joseph, MI), and phosphorus (P) was determined according to the Bray-1 procedure. Exchangeable bases, Al, and CEC were determined by the unbuffered 1 M NH<sub>4</sub>Cl method (Sumner and Miller 1996). Oxalate-extractable P (P<sub>ox</sub>), Al (Al<sub>ox</sub>) and Fe (Fe<sub>ox</sub>) were determined by the acid ammonium oxalate procedure. The modified Dithionate-Citrate-Bicarbonate (DCB) procedure described by Loppert and Inskeep (1996) was used to extract Al<sub>d</sub> and Fe<sub>d</sub>. The major modification of this procedure involved shaking the samples overnight instead of heating

## Results

The surface soil properties are presented in Table 1. The surface soils east of the Rift Valley were 0.75 pH<sub>H2O</sub> units more acidic. Total C varied significantly with site, ranging from 17.3 to 57.4 g/kg while N ranged from 1.5 to 3.8 g/kg. The relatively lower C content in the western, medium-altitude areas may be a result of the greater rate of soil organic matter decomposition, probably due to the warmer temperatures, and the inverse may be true for the higher altitudes. In addition, the influence of the type of vegetative cover could be the reason for the relatively greater C and N content in pedons KN07 and KN08. Pedon KN07 was previously under fallow (woodlot with grass under-story) and pedon KN08 was under pasture grass, probably resulting in accumulation of surface litter and below ground root debris.

**Table 1. Some chemical properties of selected Kenyan soils.**

Sample ID	Depth (cm)	pH			$\Delta$ pH	N (---g/kg---)	C	Extractable P (mg/kg)	
		H <sub>2</sub> O	KCl	CaCl <sub>2</sub>				Bray-1	Oxalate
KN01A	0-15	4.3	3.5	4.0	0.8	1.7	22.2	5	310.0
KN02A	0-20	5.0	3.9	4.3	1.1	1.6	20.0	8	330.6
KN03A	0-25	5.3	3.9	3.9	1.4	1.5	19.9	3	394.1
KN04A	0-11	6.2	4.9	4.9	1.3	1.9	25.4	3	310.4
KN05A	0-20	5.6	4.2	4.5	1.4	1.9	31.6	3	315.4
KN06A	0-20	5.1	3.8	4.2	1.3	1.6	17.3	3	187.0
KN07A	0-20	6.0	4.9	5.2	1.1	2.8	26.9	5	479.6
KN08A	0-12	5.5	4.3	4.9	1.2	2.7	39.5	9	403.8
KN09A	0-15	4.6	3.7	3.7	0.9	3.8	57.4	6	500.7
KN10A	0-20	4.6	3.6	3.9	1.0	3.2	31.3	46	4249.3
KN11A	0-25	4.7	3.8	3.9	0.9	3.5	42.5	16	511.3

The exchange properties of the surface soils are presented in Table 2. Exchangeable bases were lower in eastern than in western Kenya soils. Pedons KN02, KN07, and KN08 had greater exchangeable K than the rest.

**Table 2. Exchangeable cations and ion exchange capacity selected Kenyan acid soils.**

Sample ID	Depth (cm)	K Mg Ca Na Al					Al Saturation (%)	CEC ECEC AEC		
		(cmol <sub>c</sub> /kg)						(cmol <sub>c</sub> /kg)		
KN01	0-15	0.5	0.6	2.4	0.7	2.3	39.6	5.8	9.5	0.6
KN02	0-20	1.1	1.4	3.7	0.5	0.8	11.6	7.0	10.5	3.3
KN03	0-25	0.2	0.8	3.3	0.5	1.6	27.4	5.8	8.8	1.9
KN04	0-24	0.5	1.6	4.5	0.3	1.1	14.6	7.6	13.7	1.1
KN05	0-11	0.4	1.7	3.2	0.3	2.0	26.5	7.2	11.6	1.5
KN06	0-18	0.3	1.1	2.6	0.4	0.4	8.3	4.4	9.3	0.8
KN07	0-11	1.6	3.1	3.6	0.5	0.4	4.3	8.6	22.0	1.1
KN08	0-20	0.7	1.9	6.3	0.3	2.1	19.0	11.0	18.1	2.2
KN09	0-20	0.3	0.6	1.3	0.3	4.5	58.5	7.7	9.9	1.9
KN10	0-20	0.4	1.0	1.6	0.3	2.9	47.6	6.2	10.7	1.1
KN11	0-12	0.4	0.2	1.4	0.3	3.3	60.7	5.3	8.5	2.0

Adverse cation ratios: notably low Mg:K ratio (> 1:2) may lead to Mg deficiency; Ca:Mg ratios < 1:3 may lead to Ca deficiency, and at  $\geq$  5:1, Mg deficiency and possible P inhibition may occur (Landon 1984). Based on this criteria, soils in this study are likely to have Ca deficiency and/or possible P inhibition due to Ca:Mg imbalance (ratios < 3:1); exceptions are pedons KN01, KN03 and KN08. Also, Mg deficiency is likely to occur in pedons KN01, KN02 and KN11. The exchangeable Na levels in these soils are generally greater than expected for such highly weathered soils. It is not clear whether the extracted Na was readily exchangeable or originated from dissolution of weatherable minerals in the inorganic matrix. Exchangeable

Al ranged from 0.4 to 4.5 cmol<sub>c</sub>/kg, while aluminum saturation percentages (ASP) ranged from 4.3 to 60.7 %. Exchangeable Al levels greater than 2 cmol<sub>c</sub>/kg is generally considered excessive for many crops (Landon 1984). The ASP is a measure of the proportion of the exchange sites occupied by Al at the pH of the soil. Typically, the yield of Al-sensitive crops may not be affected much in soils with ASP values lower than 30% (Landon 1984). The ASP values of eastern Kenya soils were greater than 30%. The implications of these results to food crop production in Kenya are that: (1) sorghum, a common staple crop in the western region and (2) maize, common beans, and sweet potato which are grown in most arable parts of the country, are likely to be affected by the Al levels observed in some of these soils.

The majority of the soils had low CEC/ECEC values. The AEC values found in this experiment ranged from 0.6 to 3.3 cmol<sub>c</sub>/kg, and are significantly greater than those commonly reported for variable charge soils (Hyun *et al.* 2003; Qafoku and Sumner 2001;). Hyun *et al.* (2003) reported lower AEC values (between 0.03 and 0.92 cmol<sub>c</sub>/kg) for four Brazilian Oxisols, three volcanic ash soils from South Korea, one weathered soil from Costa Rica, and one from Indiana (USA).

The amounts of DCB extractable Fe (Fe<sub>d</sub>) and Al (Al<sub>d</sub>) were greater than the corresponding values for oxalate extractable portions of Fe (Fe<sub>ox</sub>) and Al (Al<sub>ox</sub>) (Table 3). The values of Al<sub>ox</sub> were greater than those of Fe<sub>ox</sub>. The Al<sub>ox</sub>/Al<sub>d</sub> ratios were always greater than the corresponding Fe<sub>ox</sub>/Fe<sub>d</sub> ratios.

**Table 3. Ammonium oxalate and DCB extractable Fe and Al in selected Kenyan acid soils.**

Sample ID	Al <sub>ox</sub>	Fe <sub>ox</sub>	Al <sub>d</sub>	Fe <sub>d</sub>	Al <sub>ox</sub>	Fe <sub>ox</sub>
	(.....g/kg.....)				Al <sub>d</sub>	Fe <sub>d</sub>
KN01A	4.81	3.36	10.4	93.9	0.464	0.036
KN02A	4.70	3.13	12.7	64.9	0.370	0.050
KN03A	5.83	3.51	15.6	67.5	0.374	0.052
KN04A	9.67	2.49	13.6	83.1	0.712	0.030
KN05A	7.30	2.10	22.0	105.4	0.331	0.020
KN06A	4.41	1.73	13.8	56.9	0.319	0.030
KN07A	5.12	4.85	6.3	68.6	0.810	0.070
KN08A	7.49	3.88	14.5	89.7	0.518	0.042
KN09A	7.23	5.05	18.2	110.1	0.397	0.044
KN10A	14.43	8.78	15.4	103.6	0.938	0.086
KN11A	7.35	10.22	15.5	80.8	0.473	0.127

This suggests that Al is largely present in these soils either in poorly crystalline inorganic forms or possibly as Al-organic matter complexes. Iron on the other hand, dominated the DCB extractable fractions. The Fe<sub>ox</sub>/Fe<sub>d</sub> ratios are used to assess the degree of crystallinity of Fe oxides in a soil. Low Fe<sub>ox</sub>/Fe<sub>d</sub> ratios indicate a high degree of crystallinity of Fe oxides.

## Conclusion

These results suggest that most of the Kenyan acid soils studied have low levels of essential plant nutrients, particularly exchangeable bases and P, and high levels of exchangeable Al. Soils east of the Rift Valley are significantly more acidic and their exchange sites have greater Al saturation than those west of the Rift Valley. The implications of this are twofold: (1) In order achieve increased and sustained crop yields, soil management practices that will increase nutrient availability and enhance uptake are required; and (2) Al-tolerant crop varieties are likely to do well in the Kenyan soils with high Al saturation, particularly those east of the rift Valley.

## Acknowledgements

We gratefully acknowledge funding from the McKnight Foundation, Collaborative Crop Research Program.

## References

- Clark RB (1982) Plant response to mineral element toxicity and deficiency. In Plant response to mineral element toxicity and deficiency (Eds MN Christiansen, FC Lewis) pp. 71–73. (John Wiley and Sons: New York, NY).
- Clark RB, Flores CI, Gourley LM (1988) Mineral element concentrations in acid soil tolerant and susceptible genotypes. *Comm. Soil Sci. Plan.* **19**, 1003-1017.

- Foy CD (1984) Physiological effects of hydrogen, aluminum and manganese toxicities in acid soils. In 'Soil Acidity and Liming'. (Ed F Adams) pp. 57-98. (American Society of Agronomy: Madison, WI).
- Hyun S, Lee LS, Rao PSC (2003) Significance of anion exchange in pentachlorophenol sorption by variable charge soils. *J. Environ. Qual.* **32**, 966-976.
- Landon JR (1984) 'Booker Tropical Soil Manual: A Handbook for Soil Survey and Agricultural Land Evaluation in the Tropics and Subtropics'. (Booker Tate: Longman Scientific & Technical, Harlow, UK).
- Loeppert RH, Inskeep WP (1996). Iron. In 'Methods of Soil Analysis Part 3. Chemical methods' (Eds DL Sparks. *et al.*). pp. 639-664. (American Society of Agronomy: Madison, WI).
- Qafuku NP, Sumner ME (2001) Retention and transport of calcium nitrate in variable charge subsoils. *Soil Sci.* **166**, 297-307.
- Sombroek WG, Braun HMH, van der Pouw BJA (1982) 'Exploratory soil map and agro-climatic zone map of Kenya. Scale 1:1 000 000. Exploratory Soil Survey Report No. E1.' (Kenya Soil Survey).
- Sumner EM, Miller PM (1996) Cation exchange capacity and exchange coefficients. In 'Methods of Soil Analysis Part 3. Chemical methods' (Eds DL Sparks. *et al.*) pp 1201-1229. (American Society of Agronomy, Madison, WI).
- Thomas GW (1996) Soil pH and soil acidity. In 'Methods of Soil Analysis Part 3. Chemical methods' (Eds DL Sparks. *et al.*). pp. 475-490. (American Society of Agronomy: Madison, WI).

# Development and essential oil yield and composition of mint chemotypes under nitrogen fertilization and radiation levels

Luciana W.P. Castro<sup>A</sup>, Cicero Deschamps<sup>A,C</sup>, Luiz A. Biasi<sup>A</sup>, Agnes P. Scheer<sup>B</sup> and Claudine Bona<sup>A</sup>

<sup>A</sup>Department of Agronomy, Federal University of Parana State, Rua dos Funcionários 1540, Curitiba, PR80035-050, Brazil, Email luciana.wpc@terra.com.br, cicero@ufpr.br, biasi@ufpr.br, debona@iapar.br

<sup>B</sup>Department of Chemical Engineering, Federal University of Parana State, Rua Francisco Hoffmann dos Santos, Curitiba, PR81531-990, Brazil, Email ascheer@ufpr.br

<sup>C</sup>Corresponding author. Email cicero@ufpr.br

## Abstract

Nitrogen fertilization and radiation levels affect essential oil production in aromatic plants. The objective of this study was to evaluate the vegetative development and the essential oil yield and composition of *Mentha aquatica* L. (linalool chemotype) and *Mentha x piperita* L. (linalool and menthol chemotypes) cultivated under different radiation levels (100%, 46%, and 23%) and with or without nitrogen fertilization. The essential oil samples were obtained from leaves by 3 hours of hydro-distillation and analyzed by GC/MS. Reduced leaf area, stem number, and total dry mass accumulation were found in all genetic materials subjected to the lowest level of radiation. Although reduction in radiation levels decreased essential oil yield and the percentage of its major constituents, namely, menthol, menthone, linalool, and linalil acetate, no correlation between essential oil production and plant development was observed. Nitrogen fertilization had different effects on mint chemotypes, with *M. x piperita*, linalool chemotype, being the only genetic material where nitrogen fertilization resulted in higher total dry mass under full radiation.

## Key Words

*Mentha aquatica*, *Mentha x piperita*, menthol, linalool.

## Introduction

The essential oils derived from mint are economically important, in particular due to the extensive use of the terpene menthol in the food, pharmaceutical, and perfumery industries (Farooqi *et al.* 1999). Another terpene of economic interest is linalool, which is also produced by *Mentha* species. Environmental conditions such as nutrition and radiation result in differentiated essential oil yield and composition in aromatic plants (Sangwan *et al.* 2001). Nitrogen fertilization has been shown not only to improve vegetative growth, but also to alter the essential oil yield and composition of mint (Saxena and Singh 1998). The radiation effect on essential oil composition of *Mentha* species has also been demonstrated (Fahlen *et al.* 1997). In this study, we investigated the influence of radiation and nitrogen levels on plant development and essential oil yield and composition of *Mentha aquatica*, linalool chemotype, and *Mentha x piperita*, menthol and linalool chemotypes.

## Methods

### *Plant material*

*Mentha aquatica*, linalool chemotype, and *Mentha x piperita*, linalool and menthol chemotypes were obtained from the “Genetics Resources and Biotechnology National Center” (CENARGEN), EMBRAPA, Brazil, where the plant vouchers are deposited.

### *Experimental design and growth conditions*

Greenhouse-cultivated 5–7-cm cuttings were selected and transplanted to vases containing soil, samples of which were chemically analyzed at the Soil Fertility Laboratory of UFPR (Table 1).

As recommended by Raij *et al.* (1996), the soil pH was corrected by incorporating 6.2 Mg/ha of limestone (100% PRNT), to achieve 70% of base saturation, and 40 kg/ha of P<sub>2</sub>O<sub>5</sub> and 23 kg/ha of K<sub>2</sub>O. A completely randomized design with six treatments and three replications (3 pots with 2 plants each) was used. Plants were developed under different radiation levels (100%, 46%, and 23%) and in the presence or absence of nitrogen fertilization. Treatments with nitrogen fertilization received two applications of 20 kg/ha of the element during planting and 23 days after planting. Plant development was evaluated 60 days after planting. Total dry mass was determined after stems and leaves were dried in an oven at 65°C until constant weight.

### Isolation of essential oils and analysis of volatile constituents

Samples with 100 g of fresh leaves were hydrodistilled for three hours with a Clevenger-type apparatus to determine the essential oil yield. The volatile oils were analyzed using gas chromatography coupled to mass spectrometry (Varian Inc., CP-3800 series, mass selective detector Saturn 2000 MS/MS). Individual compound identifications were made by matching spectra with those from a mass spectral library (Nist 98, Varian Inc.).

### Statistical analysis

Analysis of variance and the Tukey's test ( $P < 0.05$ ) of mean comparison procedures were performed using MSTAT-C program (Nissen 1993).

## Results

### Vegetative development

The mint chemotypes showed varying responses to the radiation and nitrogen treatments (Table 1). Even though a reduction of plant development was observed in all genetic materials exposed to the lowest radiation level, it was more intense in *M. x piperita*, linalool chemotype, wherein plants exposed to 46% of radiation presented a decrease of approximately 85% of total dry mass. A higher development was also observed in *Salvia officinalis* and *Thymus vulgaris* developed under full radiation (Li *et al.* 1996). The other two chemotypes required no nitrogen fertilization once full radiation was provided. The lack of significant results in terms of plant development in the nitrogen application treatments may be due to the level of organic matter in the soil which supplied the plant's exigencies.

**Table 1. Total dry mass (stems and leaves) of *Mentha* species with and without nitrogen fertilization under different radiation levels.**

Species/chemotype	Radiation level (%)		
	100	46	23
<i>M. aquatica</i> / Linalool			
With nitrogen fertilization	14,09 Aa	10,36 Aa	4,35 Ba
Without nitrogen fertilization	12,76 Aa	10,39 Aa	5,13 Ba
<i>M. x piperita</i> / Linalool			
With nitrogen fertilization			
Without nitrogen fertilization	20,57 Aa	3,00 Ba	1,46 Ba
<i>M. x piperita</i> / Menthol	8,53 Ab	4,83 ABa	1,82 Ba
With nitrogen fertilization	14,81 Aa	10,04 Ba	4,43 Ca
Without nitrogen fertilization	13,56 Aa	11,86 Aa	5,69 Ba

\* Means followed by the same capital letter in the rows and small letter within the columns are not significantly different by Tukey's test at  $P < 0.05$ .

### Essential oil yield and composition of *Mentha aquatica* and *Mentha x piperita*.

An increase in essential oil yield in *M. aquatica* leaves, chemotype linalool, developed with nitrogen supply under full radiation was observed (Table 2). When radiation was limited to 46%, even with nitrogen, essential oil yield was reduced. The essential oil yield of *M. x piperita*, chemotype linalool, was higher in plants developed at full radiation but without nitrogen.

**Table 2. Essential oil yield ( $\mu\text{L}\cdot\text{gr}^{-1}$  of dry mass) of *Mentha* species under different radiation and nitrogen levels.**

Species/chemotype	Radiation level (%)		
	100	46	23
<i>M. aquatica</i> / Linalool			
With nitrogen fertilization	3,99 Aa	1,27Ba	0,56Ca
Without nitrogen fertilization	1,46 Ab	0,93Ba	0,57Ca
<i>M. x piperita</i> / Linalool			
With nitrogen fertilization	2,76 Bb	3,79 Aa	-
Without nitrogen fertilization	3,64 Aa	2,09 Bb	-
<i>M. x piperita</i> / Menthol			
With nitrogen fertilization	2,63 Aa	2,21 Ba	1,42 Ca
Without nitrogen fertilization	2,50 Aa	1,93 Ba	1,56 Ca

\* Means followed by the same capital letter in the rows and small letter within the columns are not significantly different by Tukey's test at  $P < 0.05$ .



The essential oil composition of *M. aquatica* was affected by decrease of radiation levels and not by decrease of nitrogen. *M. aquatica*, linalool chemotype, under 100% radiation, presented higher concentrations of the major components of the essential oil, independently of nitrogen fertilization (Table 3). *M x piperita*, linalool chemotype, did not present significant differences in essential oil composition under different environmental conditions. The *M x piperita*, menthol chemotype, presented reduction in menthol and menthone when radiation was reduced to 46%, independently of nitrogen.

**Table 3. Essential oil constituents (%) of *Mentha* species under different radiation and nitrogen levels.**

Species	Essential oil constituent*	Radiation level (%)					
		With nitrogen			Without nitrogen		
		100	46	23	100	46	23
<i>M. aquatica</i>	Linalool	54,84	54,76	19,60	56,23	29,82	23,51
	Linalil acetate	16,75	13,36	0,00	14,69	8,18	5,78
	Total	71,59	68,12	19,60	46,99	38,00	36,29
<i>M. x piperita</i>	Linalool	59,06	61,64	-	56,23	63,48	-
	Linalil acetate	18,84	21,23	-	15,84	16,50	-
	Total	77,90	82,94	-	72,07	79,98	-
<i>M. x piperita</i>	Menthol	35,18	25,77	40,61	33,86	22,76	29,63
	Menthone	23,36	19,65	1,43	38,39	31,15	28,04
	Total	58,54	45,42	42,04	72,25	53,91	57,67

- Not enough plant material for essential oil isolation.

\* percentage.

## Conclusions

The radiation levels interfere with development, essential oil yield, and composition of mint chemotypes. Nitrogen exigencies differ among the evaluated genetic materials, indicating that once full radiation is provided, optimal plant growth can be achieved with lower nitrogen levels in the soil. Specific plant-spacing evaluation under field conditions of mint chemotypes can ensure high levels of essential oil production and quality.

## Acknowledgments

The authors acknowledge Dr. Roberto Vieira and Dr. Dijalma Barbosa from “Genetics Resources and Biotechnology National Center” (CENARGEN), EMBRAPA, Brazil, for supplying the genetic material needed for this research and to CNPq - Brazilian Agency for Research - for the financial support to the first author.

## References

- Fahlen A, Welander M, Wennersten R. (1997) Effects of light-temperature regimes on plant growth and essential oil yield of selected aromatic plants. *Journal of Science of Food and Agriculture* **73**, 111-119.
- Farooqi AHA, Sangwan NS, Sangwan RS (1999) Effect of different photoperiodic regimes on growth, flowering and essential oil in *Mentha* species. *Plant Growth Regulation* **29**, 181-187.
- Li Y, Craker LE, Potter T (1996) Effect of light level on essential oil production of sage (*Salvia officinalis*) and thyme (*Thymus vulgaris*). *Acta Horticulture* **426**, 419-426.
- Nissen O (1993) ‘MSTAT-C A microcomputer for design, management, and analysis of agronomic research experiments’. Version 2.11 (East Lansing: Michigan State University).
- Raij B, Cantarella H, Quaggio JA, Furlani AMC (1996) Fertilization Guideline for São Paulo State. (Campinas: Instituto Agrônômico e Fundação:Brazil) (in Brazil)
- Saxena A, Singh JN (1998) Effect of irrigation, mulch and nitrogen on yield and composition of Japanese mint (*Mentha arvensis*) oil. *Indian Journal of Agronom* **43**, 179–182.
- Sangwan NS, Farooqi AHA, Shabih F, Sangwan RS (2001) Regulation of essential oil production in plants. *Plant Growth Regulation* **34**, 3-21.

# Effect of different genotypes of flue-cured tobaccos and different culture methods on K nutrition in rhizospheric and non-rhizospheric soils

Tiezhao Yang<sup>A</sup>, Juan Lin, Zhixiao Yang, Zhengguang Zhai, Xia Wang and Yunji Zhu<sup>B</sup>

<sup>A</sup>Faculty of Agriculture, Henan Agricultural University, Zhengzhou, Henan, China, Email yangtiezhao@126.com

<sup>B</sup>Department of Resource and Environment, Henan Agricultural University, Zhengzhou, Henan, China, Email hndzyj@126.com

## Abstract

The experiment was carried out to investigate the effect of Cation Exchange Capacity (CEC) on the variation of readily available K content and non-exchangeable K content in rhizospheric and non-rhizospheric soils with three different genotypes (i.e. Nongda 202, K326 and NC89) of flue-cured tobaccos (*Nicotiana tabacum* L.) in soil and sand culture. The activating effects of root exudates and population of rhizospheric microbes on K content of soil was also investigated. Results show that the readily available K content in both rhizospheric and non-rhizospheric soils varies for difference genotypes, i.e. Nongda202 > K326 > NC89. Root exudates activate K content in the soil to different levels with maximum activation observed for Nongda202. The difference is significant among all three genotypes. The fungi population in the rhizospheric soils is larger compared to that in non-rhizospheric soils for all three genotypes. There were significantly higher fungi populations in Nongda202 rhizospheric soils than that of K326 and NC89. The difference between latter two was not significant. The difference in population was significant in rhizospheric bacteria but not in actinomycete. Nongda 202 shows better CEC than NC89 and K326 with insignificant difference between latter two. Therefore, the physiological properties of the roots should be taking into account when breeding K-enriching tobacco varieties.

## Key Words

Flue-cured tobacco, potassium, root exudates, soil microbe, cation exchange capacity (CEC).

## Introduction

Potassium content of tobacco leaves is closely related to the maturity, aroma and taste of tobacco leaves, as well as safety of cigarette products, has been treated as one of the most important indicators of tobacco quality for many years. In most areas of China, especially the northern part, average potassium content of tobacco leaves can hardly exceed 1.5%, which is the major problem for improving quality of tobacco leaves. Previous studies show that to significantly increase the potassium content of tobacco leaves, two to three times more potassium fertilizer compared to the optimum amount is required. However, this approach is limited due to the shortage of potassium fertilizer resources in mainland China. Previous investigations conducted on crops such as wheat, corn, and *Amaranthus hypochondriacus* demonstrate that genotype with high potassium efficiency have enormous potential at improving potassium content (plant-available K) of soil and the utilization efficiency of potassium fertilizer. The soil in northern China (to the north of Yangze River) contains a considerably amount of readily available K and is rich in Potassium content, which can potentially provide large amount of Potassium. However, due to the calcareous nature of soil, especially the strong basicity and high Calcium content, the availability of Potassium content is poor. Moreover, potassium fertilizer tends to be immobilized by the particle agrotpe and frequent change of humidity, which also affects the Potassium transmission into of tobacco leaves. Therefore, breeding and selection of genotype that can efficiently utilize the potassium content in the soil is not only important in improving the Potassium content in tobacco leaves, but also beneficial in reducing the production cost and resources used.

The rhizospheric Potassium concentration of a plant mainly depends on its root characteristics, especially the Cation Exchange Capacity (CEC), root exudates, and population and species of rhizospheric microbes. Chui et al. demonstrated that the Potassium efficient genotype of ramee exhibits comparably high CEC. Potassium efficient genotype of *Amaranthus hypochondriacus* can produce a local Potassium concentration in a region surrounding the rhizospheric area (Chui and Li 2000). A larger population of rhizospheric microbes and more active root exudation is observed compared to other genotypes. Currently, the studies of plant Potassium nutrition mainly focus on the aspects of physiological property and genetic improvement. The effect of the root characteristics for difference types of Potassium efficient tobacco leaves, root exudates, population and species of rhizospheric microbes are not investigated. To facilitate the selection and breeding of high Potassium content tobacco leaves, this study looks into the difference of root exudates, rhizospheric microbes and root characteristics between the Potassium efficient and general genotypes.

## Methods

### *Experiment materials*

The soil sample used is light-loamy Chao soil, which was collected at depth of 0-20cm from surface soil at Science Park in Henan Agricultural University. The soil has been tested: organic matter 12.20 g/kg, N 0.84 g/kg, P<sub>2</sub>O<sub>5</sub> 0.12 g/kg, readily available K 125 mg/kg, slowly available K 681 g/kg, pH 7.47. The flue-cured tobacco samples are Nongda 202 (ND202), K326 and NC89, in which ND202 is the product which is potassium rich. The inheritance of this product is stable after directional selection for over 10 generations and the rest are comparison products. All cultivars were raised seedling in plates filled with growing media and watered in a daily basis to keep certain humidity. The tobacco plants are transplanted to soil culture and sand culture when 6 leaves have grown.

### *Experiment design*

Soil culture experiment was carried out by a pot method. Pots are 27 cm in radius, 30 cm in height. Every pot was filled with 75 g compound fertilize with 15% of N, P<sub>2</sub>O<sub>5</sub> and K<sub>2</sub>O by randomized block design with 3 replications. Root-bags were used to raise tobacco plants. The plants with 6 visible leaves and good growth consistency were transplanted into root bags made by 300 mesh polyamide net in the size of 14 cm x 14 cm x 14 cm (~500 g soil). After 40 days, tobacco plants were fast growing stage and filled root bags with roots. This is the best time to compare the variation of different genotypes for element uptake due to active metabolism and a large amount of element uptake. A 2 cm upper layer of soil from the root bags was removed. The remaining soil inside bags is rhizospheric soil; the soil outside of bags is non-rhizospheric soil. Contents of available K and non-exchangeable K, as well as the populations of bacteria, fungus and actinomycete were measured in the two kinds of soils.

A sand culture experiment was carried out by the pot method, in which the pots were filled with 1.5 kg quartz sand and watered by Hoagland solution once a day. After 40 days, tobacco plants with good growth consistency were collected for different genotypes. Samples are cultured in 500 ml de-ionized water replaced every 24 hours. The replaced de-ionized water was collected for 3 days, fitted with a SAD-4 resin bar at the flow rate of 5ml/min and then resin was washed by de-ionized water with a volume of 10 times that of the bars, in order to eliminate the nutrient content. Methanol was used to wash off exudate from roots, cold-dried and mixed with high purity water (30 ml). 0.1 mol/L HCL solution was used to alter the pH value to 2.0, get rid of water phase after extraction 3 times by ether. 0.1 mol/L NaOH was used to alter the pH value to 8.0, and then extracted 3 times. Ether was evaporated off, mixed with a small amount of methanol that add de-ionized water added to 5 ml. Concentrated root exudates were thus acquired.

The soil microbes were measured by means of a diluting plate. Beet extract, peptone and agar were used as medium to culture bacteria. The actinomycete and fungi were cultured by Gauss's synthetic agar and Martin medium respectively. Cation exchange capacity (CEC) was measured (Chui and Li 2000). SPSS 12.0 was used for analysing the data by ANOVA and comparative analysis.

## Results

### *Effect of different genotypes on different types of K content at rhizospheric soil*

Table 1 shows available potassium and non-exchangeable potassium in rhizospheric soil from the 3 genotype tobaccos are lower than that of non-rhizospheric soil. ND202 has the highest available K content with the 18.47% and 13.63% exceeding to NC89 and K326 respectively. Meanwhile, ND202 contains the much lower amount of non-exchangeable K than the other two varieties. The K content in non-rhizospheric soil shows significant difference with ND202 containing highest amounts of available K (156.5 mg/kg).

**Table 1. Contents of available and non-exchangeable potassium in rhizospheric soils for flue-cured tobaccos of different (K<sub>2</sub>O mg/kg).**

Genotypes	Rhizospheric soil		Non-rhizospheric	
	Available potassium	Non-exchangeable potassium	Available potassium	Non-exchangeable potassium
ND202	95.4 aA	750.1 bB	156.5 aA	766.5 aA
NC89	84.3 bA	855.2 aA	138.7 bB	708.7 Bb
K326	84.0 bA	845.5 aA	132.1 bB	789.8 aA

Notes: Within column, means followed by the same small or capital letters are not significantly different at 5% or 1% levels by LSD test, respectively. The same as below.

### *Effect of different genotypes on soil K activation of root exudates of flue-cured tobaccos*

Table 2 shows all 3 genotypes of tobaccos have higher amount of available potassium extracted from root exudates than the comparison sample (pure water). The differences are 45.6%, 35.8% and 24.4% respectively. This indicates that the root exudates from tobacco plant play a role on enhancing the available potassium content of soils.

**Table 2. Soil K activation of root exudates of flue-cured tobaccos different in genotype (K<sub>2</sub>O mg/kg).**

Genotype	Available potassium
ND202	239.8 aA
K326	223.8 bB
NC89	205.2 cC
Deionized water	164.7 dD

### *Effect of different genotypes on soil microbes in rhizospheric soils for flue-cured tobaccos*

Table 3 shows the number of fungi in rhizospheric soil are higher than that in non-rhizospheric soils of ND202, K326 and NC89, with increments of 26.5%, 6.5% and 8.6% respectively. The fungi population in the rhizospheric soils is larger compared to that in non-rhizospheric soils for all three genotypes. Nongda202 has significantly higher fungi population than K326 and NC89. The difference between latter two was not significant. The difference in population was significant for rhizospheric bacteria but not for actinomycete.

**Table 3. Numbers of soil microbes in rhizospheric soils for flue-cured tobaccos different in genotype (number/g dry soil).**

Genotypes	Rhizospheric soil		
	Fungi number	Bacteria number	Actinomyces number
ND202	4.728E+04 aA	1.224E+06 bB	9.574E+06 aA
NC89	4.053E+04 bB	1.6144E+06 aA	1.012E+07 aA
K326	3.971E+04 bB	1.0695E+06 cC	1.027E+07 aA

### *Effect of different genotypes on cation exchange capacity of the roots and potassium content for organs of flue-cured tobaccos*

Table 4 illustrates the CEC of the roots and potassium content in root, stalk and leaf of tobaccos. Nongda 202 shows better CEC than NC89 and K326 with insignificant difference between latter two.

**Table 4. Cation exchange capacity of the roots and potassium content in organs of flue-cured tobaccos different in genotypes.**

Genotypes	CEC(me100/g)	Content of potassium (K <sub>2</sub> O g/kg)		
		Root	Stalk	Leaf
ND202	51.0 aA	5.4 aA	11.1 aA	33.6 aA
NC89	43.7 bB	4.9 bA	11.2 aA	30.2 bB
K326	43.4 bB	4.9 bA	10.8 aA	29.8 bB

## **Conclusion**

The highest amount of available potassium content were in rhizospheric soil of ND202 but there was relatively low non-exchangeable potassium. The root extraction from the ND202 root system shows the largest activation energy for potassium content in soil, resulting in excess non-exchangeable potassium and shifted dynamic balance of these two kinds of potassium in soils. On the other hand, the highest concentration of available potassium was found in rhizospheric soil of ND202. This may due to the root exudates which help transport available potassium from non-rhizospheric to rhizospheric soil. Extracts from roots of tobacco plants provide a medium for multiplication of fungi. The higher activation ability of potassium is related to the large amount of root exudates. It is also proved that cation exchange capacity affects potassium absorption by plants directly. The generation of potassium ions in free space enhances the indirect absorption of potassium and promotes the transport of potassium to upper parts of plants.

## **References**

- Bao SD (2000) The analysis of soil agro chemistry. *Beijing Agriculture Press* 103-109. (In Chinese)
- Cao ZH, Hu GS, Zhou XR (1993) Potassium supplying characteristics in different soils and potassium fertilizer effective applying in flue-cured tobacco. *Tobacco Sci. and Tech* **2**, 33-37. (In Chinese)
- Chui G X, Li ZD (2000) Relationship between potassium absorption and root parameters of different

- genotypes of ramie. *Research of Agricultural Modernization* **21**, 371-375. (In Chinese)
- Huang J G, Yang BJ, Yuan L (1995) Kinetics of k<sup>+</sup> absorption by various wheat varieties. *Plant Nutrition and Fertilizer Science* **3**, 38-43. (In Chinese)
- Mitchel JT (1988) Development of microbial community association with tobacco root systems. *Soil Biochemical* **120**, 137-144.
- Wang DM, Fang SF (1999) Study on the effect of K nutrition on physiological change and maturity of flue-cured tobacco in the course of mature. *Plant Nutrition and Fertilizer Science* **5**, 244-248. (In Chinese)
- Yang TZ, Fang J H (2006) The roots characteristics of different genotype flue-cured tobacco varieties in absorption potassium. *Acta Agricultural Boreali-Occidentalis Sinica* **15**, 41-43.
- Yang TZ, Peng YF (2006) Potassium accumulation characteristics of rich-potassium genotypic flue-cured tobacco. *Plant Nutrition and Fertilizer Science* **12**, 750-753. (In Chinese)

# Genotypic variation in micronutrient and cadmium concentrations in grains of 35 upland rice cultivars

Milton F. Moraes<sup>A,B</sup>, Cassio H. Abreu Jr<sup>C</sup>, Jonathan J. Hart<sup>D</sup>, Ross M. Welch<sup>D</sup>, and Leon V. Kochian<sup>D</sup>

<sup>A</sup>Department of Genetics, Luiz de Queiroz College of Agriculture, USP, Piracicaba, Brazil, Email [moraesmf@yahoo.com.br](mailto:moraesmf@yahoo.com.br)

<sup>B</sup>Federal University of Sao Carlos, UFSCar, Sorocaba Campus, Sorocaba, Brazil.

<sup>C</sup>Plant Nutrition Laboratory, Center for Nuclear Energy in Agriculture, USP, Piracicaba, Brazil.

<sup>D</sup>Cornell University, Tower Road, Robert W. Holley Center for Agriculture and Health, USDA-ARS, Ithaca, NY, USA.

## Abstract

Rice is the primary food for half of the world population and in Brazil it is the most consumed cereal. Plant breeders have selected rice cultivars for high micronutrient density traits, but there is a need to include other elements that can affect micronutrient bioavailability, such as cadmium (Cd). The study was conducted with the purpose of evaluating the relationships among Cd, zinc (Zn), iron (Fe), and selenium (Se) concentrations in grains of upland rice cultivars. Thirty-five upland rice cultivars were grown to maturity in a pot soil experiment under greenhouse conditions. Cadmium and micronutrient concentrations in grains ranged widely, but showed a close relation with grain yield. While the grain-Cd concentration increased with the increase of grain yield, an opposite relationship was found for grain micronutrient concentrations, which declined with increased grain yield. It appears that rice plants use different mechanisms to regulate the accumulation of toxic and essential heavy metals into grains.

## Key Words

Grain-Cd concentration, heavy metals, translocation, uptake, soil pollution, human health.

## Introduction

Micronutrient malnutrition is today the major human health concern around the world, especially in developing countries. According to the World Health Organization more than 2 billion people may be anemic as a consequence of Fe deficiency (Allen *et al.* 2006). It has been estimated that one fifth of the population ingests inadequate amounts of zinc (Hotz and Brown 2004) and Combs Jr (2001) has estimated that between 0.5 and 1.0 billion people could be deficient in selenium. Development of crop plants with high Fe, Zn and Se in their edible parts will benefit from a better understanding of processes related to micronutrient acquisition (Welch and Graham, 2004). Factors related to environment, adaptation, and selection can increase or decrease the absorption of a given element in favor of another. However, one given gene or group of genes may control the absorption of a single or more elements (McLaughlin *et al.* 1999) and anti-nutritional factors such as Cd can increase in edible parts. Little is known about the efficiency of acquisition and utilization of micronutrients and their relationships to anti-nutritional factors. The objective of this study was to evaluate the relationship between micronutrient and cadmium accumulation in upland rice grains of 35 cultivars.

## Methods

A pot experiment was carried out in a greenhouse at the Center for Nuclear Energy in Agriculture (CENA), University of Sao Paulo (USP), Piracicaba, SP, Brazil. Pots with 3 dm<sup>3</sup> of an acid Oxisol received lime and fertilizers as recommended for upland rice and after one month seeds were sown. Micronutrients and Cd were supplied together with fertilizers at rates (mg/dm<sup>3</sup>): Se - 0.1, Zn - 3.0 and Cd - 1.0. Thirty-five upland rice cultivars were selected according to the following characteristics: old and new cultivars, duration of life cycle, high and low content of minerals in grains, yield, type and color of grain (red, black or white). Three plants per pot with three replicates were used and after maturation, the plants were harvested. Samples of brown rice grains were digested in HNO<sub>3</sub> + H<sub>2</sub>O<sub>2</sub> and analyzed by ICP-MS. A reference material (NIES N° 10, Rice Flour-Unpolished) was used to assure the quality of analysis results.

## Results

Large differences were observed in both grain yield and concentrations of Cd, Fe, Zn and Se in rice grains (Table 1). There was a significant direct relationship between grain yield and grain-Cd concentration. In contrast, an opposite relationship was observed among the grain yield and grain micronutrient concentration (Table 1).

**Table 1. Grain yield, concentration of Cd and micronutrients and their relationship in grains of 35 upland rice cultivars.**

Cultivars <sup>(1)</sup>	Grain yield g/pot	Grain concentration			
		Cd	Fe	Zn	Se
		mg/kg			
					µg/kg
IAC 4440	24.0	1.76	20.5	24.4	57
PB 11	13.7	1.54	15.8	25.2	35
PB 05	21.8	1.53	15.8	36.0	17
BRSMG Relâmpago	11.5	1.23	19.3	32.9	16
BRSMG Caravera	15.9	1.21	21.3	25.4	15
BRSMG Curinga	17.3	1.04	31.3	36.6	74
Pérola	1.5	1.03	25.0	34.2	64
Bonança	13.0	0.95	15.9	37.2	42
Jaguari	1.7	0.93	25.1	44.7	48
Primavera	5.5	0.79	21.4	45.1	53
IAC 201	9.6	0.74	29.7	33.5	61
IAC 600	1.6	0.67	23.5	39.0	47
Gurani	11.9	0.65	16.9	37.7	56
Caiapó	9.3	0.61	18.3	43.2	63
Bico ganga	8.4	0.59	25.2	43.8	27
IAC 435	1.8	0.55	23.0	25.7	63
BRS Talento	12.9	0.53	31.0	34.8	55
Canastra	7.1	0.53	25.7	43.3	73
PB 01	16.0	0.53	15.2	30.0	17
Arroz preto	9.1	0.50	27.5	42.3	47
IAC 165	7.0	0.49	25.6	39.5	58
BRSMG Conai	13.2	0.48	15.9	34.1	40
Carajás	12.3	0.48	14.5	32.1	56
IAC 47	6.6	0.46	23.3	41.1	44
IAC 202	11.3	0.42	21.1	34.3	63
Pratão	1.7	0.38	22.6	41.6	39
Beira campo	13.4	0.36	19.2	40.4	36
Maravilha	6.4	0.32	17.1	37.6	42
IAC 25	9.2	0.32	21.7	37.5	48
Batatais	1.0	0.31	26.0	29.6	49
Dourado precoce	2.6	0.30	31.3	44.5	85
IAC 4	2.4	0.29	25.1	39.3	122
Cateto	2.4	0.28	20.2	40.6	40
IAC 1246	8.2	0.19	29.1	42.6	115
Cateto seda	6.9	0.17	31.4	39.5	71
DMS, Tukey 5%	7.9	0.13	5.2	6.5	15
		Pearson's correlation coefficient			
Grain-Cd concentration	0.56***	-	-	-	-
Grain-Fe concentration	-0.34***	-0.28***	-	-	-
Grain-Zn concentration	-0.40***	-0.47***	0.31***	-	-
Grain-Se concentration	-0.31***	-0.39***	0.52***	0.28***	-

<sup>(1)</sup>Following rates of the elements were applied (mg/dm<sup>3</sup>): Se - 0.1, Zn - 3.0 and Cd - 1.0; \*\*\*significant at 1% level.

In addition, significant negative correlations were found between the concentrations of Cd and micronutrients in rice grains. However, just positive relationships were observed among the concentration of micronutrients in upland rice grains (Table 1). High grain yields may lead to a reduction in micronutrient grain concentration as suggested by recent studies (Garvin *et al.* 2006; Murphy *et al.* 2008). Thus, it was expected that grain-Cd concentration would also be low in the cultivars that showed high yields, but actually an opposite result was found. So it seems that rice plants may use different mechanisms to regulate the accumulation of toxic and essential elements into the grains, as suggest by Kubota *et al.* (1992).

## Conclusion

Cadmium and micronutrient accumulation in upland rice grains seem to be differentially controlled as there was an opposite relationship among their concentration. Breeding programs can easily screen rice plants for both low cadmium concentration and high micronutrients density traits.

## Acknowledgements

The authors thank FAPESP (Grant # 04/15897-7), CAPES/PDEE (Grant # 2988-07-0) and USDA-ARS/Cornell for providing fellowship to M.F. Moraes and funding to this research.

## References

- Allen L, Benoist B, Dary O, Hurrell R (2006) Guidelines on Food Fortification with Micronutrients. 341p. (WHO/FAO: Geneva).
- Combs Jr GF (2001) Selenium in global food systems. *British Journal of Nutrition* **85**, 517-547.
- Garvin DF, Welch RM, Finley JW (2006) Historical shifts in the seed mineral micronutrient concentrations of US hard red winter wheat germplasm. *Journal of the Science of Food and Agriculture* **86**, 2213-2220.
- Hotz C, Brown KH (2004) Assessment of the risk of zinc deficiency in populations. *Food and Nutrition Bulletin* **25**, S130-S162. (Supplement 2).
- Kubota J, Welch RM, Campen DR (1992) Partitioning of cadmium, copper, lead and zinc amongst above-ground parts of seed and grain crops grown in selected locations in the USA. *Environmental Geochemistry and Health* **14**, 91-100.
- McLaughlin MJ, Parker DR, Clarke JM (1999) Metals and micronutrients - food safety issues. *Field Crops Research* **60**, 143-163.
- Murphy KM, Reeves PG, Jones SS (2008) Relationship between yield and mineral nutrient concentrations in historical and modern spring wheat cultivars. *Euphytica* **163**, 381-390.
- Welch RM, Graham RD (2004) Breeding for micronutrients in staple food crops from a human nutrition perspective. *Journal of Experimental Botany* **55**, 353-364.



# Long-term fertilization effects on grain yield and soil fertility in the paddy soil of Yangtse Delta in China

Dejian Wang, Can Wang and Gang Zhang

Institute of Soil Science, Chinese Academy of Sciences, Nanjing, China, Email djwang@issas.ac.cn

## Abstract

A long-term field experiment under different fertilizer N rates has been conducted to explore the optimal N application rates for a rice-wheat system and soil fertility change in the Yangtse Delta region where excessive applications of N fertilizer have resulted in reduced N recovery rate and environment pollution. Results of 11-years experiment showed that fertilizer N application rate had a significant effect on crop yield and soil fertility. Rice yield varied over time from 6.0 to 8.3 t/ha for the fertilization N and from 4.1 to 6.5 t/ha for nil N, and wheat yield varied from 2.3 to 6.5 t/ha for the fertilization N and 0.7 to 3.4 t/ha for nil N and control. The optimal N application rate of high grain yield ranged from 185 to 225 kgN/ha for rice and was about 180 kgN/ha for wheat. SOM and total soil nitrogen (TN) increased with the increase of N application rate, but there were no significant difference ( $P < 0.05$ ) under different N application rates. Soil available N had a slight increase with N application rate, but soil Olsen-P and available potassium was declined with the increase of N application rate. These show that this paddy soil has a strong buffer capacity.

## Key Words

Rice-wheat system; long-term fertilization; N-Fertilizer; grain yield; soil fertility.

## Introduction

The rice-wheat rotation is one of largest agricultural production system of the world, occupying 70~80% productive land in Yangtse Delta region in China. Some few reports, however, indicate that the system is under production fatigue as yields have started declining due to continuous rice-wheat cultivation (Yadav, 2000). Farmers have resorted to using higher (550-600 kgN/ha/year) than the recommended doses of N fertilisers to maintain previously attained yield levels (Wang, 2004), which has resulted in reduced N recovery rate and environment pollution. Monitoring long-term fertilization effect on crop yield and soil fertility changes is important for maintaining the system productivity (Ladaha 2003). Although there have been many field trials on fertilizer yield responses in China, most of these studies have been carried out within a short period of time and can provide only preliminary fertilizer recommendations, which need further calibration through multi-year field experiments (Fan 2005). However, most of long-term experiments are too simple to provide fertilizer recommendations. Although there have been some long-term experiments in nutrient gradient (KBS LTER 2009), few of the results are well documented in China. The experiment reported here was begun in 1998 with different fertilizer-N rates at Changshu, central place of the Yangtse Delta region, China. The study aimed to (1) examine long term yield variation for different N application rates, and (2) monitor soil fertility changes.

## Methods

### *Experimental site*

A long-term field experiment has been conducted since June 1998 at the Changshu National Agro-ecological Experimental Station (31°32.93'N, 120°41.88'E), situated in Changshu Municipal, Jiangsu Province, China. The current agricultural practice in this region is an intensive double-cropping system consisting of irrigated summer rice and upland winter wheat. Gleyed paddy soil is Eqiaquepts (US Taxonomy) with an average SOM 35.0 g kg<sup>-1</sup> and clay loam texture over 0–30 cm depth. The top 15 cm of soil taken from the experiment starting had the following characteristics: pH 7.4, SOM 36.5 g/kg, total N (TN) 2.05 g/kg, total P (TP) 0.71 g/kg, total K (TK) 22.1 g/kg, available P (AP) 7.7 g/kg, and available K (AK) 121 g/kg.

### *Experimental design and treatments*

The field experiment had 6 treatments of N<sub>0</sub>, N<sub>1</sub>, N<sub>2</sub>, N<sub>3</sub>, N<sub>4</sub> and control (CK), with fertilizer N rate being 0 (0), 180 (135), 225 (180), 270 (225), 315 (270) and 0 (0) kgN/ha, respectively for rice crops (wheat), and P application rate 26 (39) kg/ha and K application rate 94 (94) kg/ha for all the treatments except for CK,

which received nil fertilization. The experiment had four replicates with plots, 32.5 m<sup>2</sup> each, arranged randomly in rows. For both rice and wheat crops, the urea application was 40%-50% basal, 20% topdressed at tillering, and 30%-40% topdressed at panicle initiation (PI) stage. The P fertilizer, as superphosphate, was applied totally as basal. The K fertilizer, as potassium chloride, was applied 50% basal, and 50% topdressed at PI stage. Generally, two or three rice seedlings (25-30 days old) were transplanted to puddled field at 25 cm\*20 cm spacing and wheat (100~120 kg seed/ha) was sown by broadcasting. Crops were harvested manually close to the ground and all harvested biomass was removed from the plots. Grain yields were determined by harvesting half area at centers of the plots and were adjusted to 14% moisture.

#### Soil sampling and analysis

Composite soil samples (5 soil core samples/plot, 0-15 cm depth) were collected after rice harvested each year. The samples were air-dried, sieved (<2 mm) and stored for analysis of general soil properties. Representative samples were used to determine SOM, TN, TP, and available NPK, 1M NaOH hydrolyzed nitrogen (AN), 0.5M NaHCO<sub>3</sub> extractable P (AP) and 1N NH<sub>4</sub>OAc extractable K (AK), following the methods of Lu (2000)

#### Data analyses

Data were statistically analyzed by one-way ANOVA and significant differences were distinguished by LSD test at P < 0.05 level (SPSS 11.5).

### Results

#### Effect of N application rate on yield of rice and wheat

Rice yield varied over time from 6.0 to 8.3 t/ha for N fertilization (as N1-N4 hereafter) and from 4.1 to 6.5 t/ha for nil N. Yields were lower during 1999~2001 and 2003~2005, mostly resulting from excess rain and lower temperature (Figure 1a). The results of 11 years of experimentation indicated that the rice yield is related to N application. Among four treatments of fertilization N, rice yield of treatment N3 (270 kgN/ha) was close to the highest value, but the increase in yield was very limited when N application rate went beyond treatment N1 (180 kgN/ha) and yields for only 2 of 11 years had significant differences (P<0.05) with N1 and N2 (225 kgN/ha). So the optimal N application rate for rice on this paddy soil may range between 185 and 225 kg/ha. Rice yield for treatment N0 followed a trend of increase from 4.1 (1999) to 6.2 t/ha (2008), which showed that there was a nitrogen contribution from an environment source. Monitoring indicated that the experiment field received about 35.3 kg N/ha/year from rain and irrigation during the 2005~2006. In addition, no significant difference was observed between CK and N0 in the first three years, showing that among the three macronutrients, NPK, N fertilizer has the most effect on yield of rice. For the wheat (Figure 1b), yield fluctuated much more than for rice, it varied from 2.3 to 6.5 t/ha for treatment of N application and 0.7 to 3.4 t/ha for treatment of N0 and CK. The yields of treatment N1-N4 were significantly higher than treatments N0 and CK, but most of the yields had no significant difference among fertilization N treatments, and between N0 and CK. Optimal fertilizer N rate for high yield wheat also fluctuated from 180 to 225 kgN/ha, but mostly was 180 kgN/ha.

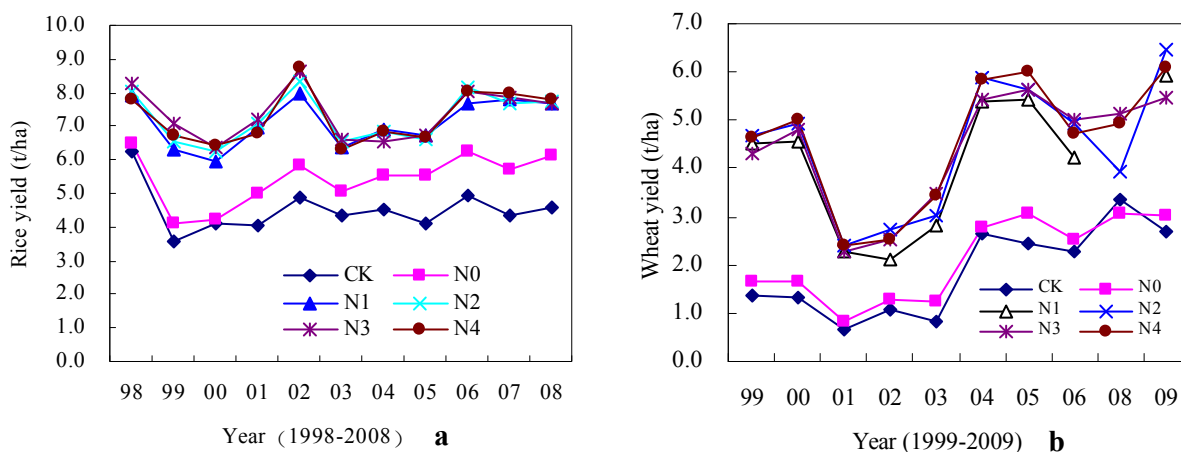

**Figure 1. Variation in yield of rice and wheat under the different N application rates from 1999 to 2009**

### Impact of N application rate on soil fertility

The soil SOM and TN (taken in 2008 after rice harvesting, 0-15 cm depth) increased with increasing of N application rate after ten-year fertilization (Figure 2a) and highest values appeared in treatment N3 with 41.6 and 2.44 g/kg for SOM and TN, respectively. When the N rate went beyond the N3, both SOM and TN declined, but there were not significant differences among N fertilization treatments (N1-N4). A similar result was also reported for a calcareous paddy soil (Shena *et al.* 2004). For rapidly available soil NPK (Figure 2b), the AN had a slight increase with N application rate, but only the treatment N4 was a significantly higher than the other treatments. The content of AP and AK declined with increasing N application rate. Treatment N0 had a highest values of AP and AK with 36.1 and 199 mg/kg, respectively, which were significantly higher than for treatments of N fertilization and CK, however, there were not significant difference among N fertilization treatments. Compared to the initial soil, soil AP and AK increased about 140~200% and 19.0~24.3% for N treatments, respectively. Soil AP in control decreased 56%, however, AK changed little, being attributed to the soil being potassium rich.

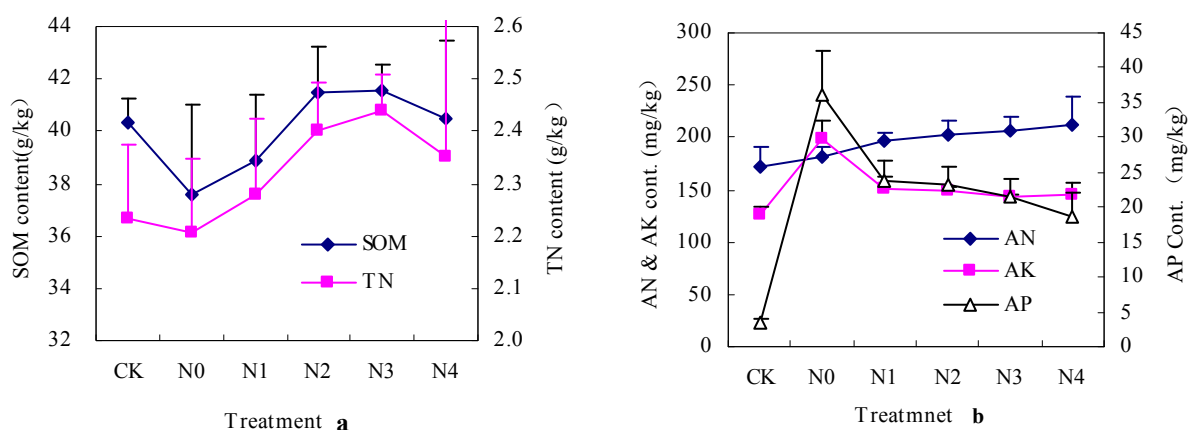

Figure 2. Variation in soil nutrients for the different N application rates in 2008

### Conclusion

Continuous (11 years) application of different N rates had a significant effect on crop yield and soil fertility. The rice yield was more stable than wheat yield over time, and the optimal N application rate for high yield ranged from 185 to 225 kgN/ha for rice and was about 180 kgN/ha for wheat in this area. The SOM and TN increased with the increase of N application rate, but there were not significant difference ( $P < 0.05$ ) among different N application rates. The AN showed a slight increase with N application rate, but soil AP and AK declined with increasing of N application rate. These data show that N fertilizer rate if reduced properly has no significant effect on grain yield and soil fertility in the rice-wheat system of this region.

### References

- Fan TL (2005) Long-term fertilization effects on grain yield, water-use efficiency and soil fertility in the dryland of Loess Plateau in China. *Agriculture, Ecosystems and Environment* **106**, 313–329.
- KBS LTER (2009) Long-term experiments-fertility gradient. [http://lter.kbs.msu.edu/about/experimental\\_design.php](http://lter.kbs.msu.edu/about/experimental_design.php)
- Ladha JK (2003) How extensive are yield decline in long-term rice-wheat experiments in Asia? *Field Crops Research* **82**, 159-180.
- Lu RK (2000) Soil Agricultural Chemistry Analysis (In Chinese). (Eds RK Lu) pp. 146-195. (Agricultural Science and Technique Press: Beijing).
- Shena J, Li R, Zhang F (2004) Crop yields, soil fertility and phosphorus fractions in response to long-term fertilization under the rice monoculture system on a calcareous soil. *Field Crops Research* **86**, 225–238.
- Wang DJ, Liu Q, Lin JH, Sun RJ (2004) Optimum Nitrogen use and reduced nitrogen loss in the Yangtze Delta. *Environmental Geochemistry and Health* **26**, 221–227.
- Yadav RL, Dwivedi BS, Prasad K (2000) Yield trends, and changes in soil organic-C and available NPK in a long-term rice-wheat system under integrated use of manures and fertilisers. *Field Crops Research* **68**, 219-246.

# Optimisation of nutrient transport processes by plants -boron transport as an example

Toru Fujiwara<sup>A</sup>, Mayuki Tanaka<sup>A</sup> and Kyoko Miwa<sup>B</sup>

<sup>A</sup>Biotechnology Research Center, The University of Tokyo, Tokyo, Japan, Email atorufu@mail.ecc.u-tokyo.ac.jp, tanakamayuki@yahoo.co.jp

<sup>B</sup>CRIS, Hokkaido University, Sapporo, Japan, Email miwakyoko@cris.hokudai.ac.jp

## Abstract

Boron is an essential micronutrient for plants and is also toxic in high concentrations. In a number of countries, boron deficiency and toxicity hamper agricultural production. One of the strategies to overcome the problem is to improve boron transport/utilization properties of crop plants. For this it is important to understand boron transport mechanisms at the molecular level. Boron transporters were not known until several years ago. We identified BOR1 as the first boron transporter required for efficient xylem loading of boron (B). Arabidopsis and rice have seven and four BOR1 or BOR1-like genes, all likely to encode efflux transporters, with different physiological functions and location within the cell. We also identified NIP5;1, a protein similar to aquaporin, as a transporter required for efficient B uptake. Expression of BOR1 and NIP5;1 is both upregulated under B deficient conditions but with different mechanisms. BOR1 accumulates in plasma membrane under low B conditions, and degraded through endocytosis under sufficient B supply. NIP5;1 is transcriptionally upregulated under low B conditions. Recently we have been successful in generating transgenic plants that are tolerant to low or high boron. In rice, OsBOR1 is required for efficient boron uptake and growth under B-limitation.

## Key Words

Nutrient transporters, boron, growth improvement, NIP, BOR, transgenic plants.

## Introduction

The essentiality of boron in plants was first described in 1923 (Takano *et al.* 2008, Miwa *et al.* 2009 for review). One of the roles of boron in plants was identified through biochemical and molecular biological analysis to be the crosslinking of pectic polysaccharides, rhamnogalacturonan II (RG-II) molecules. Boron is likely to have other roles as it has been demonstrated that animals and bacteria, that do not have RG-II also require boron. In agriculture, boron deficiency is a major problem that delays crop growth. Typical symptoms of boron deficiency include rapid cessation of root elongation, reduced leaf expansion and reduced fertility. These are mainly due to reduced cell expansion and this corresponds to the roles of boron in cell wall. Boron toxicity is also an important issue. Soils with toxic levels of boron are distributed in arid or semi-arid area and it also affects food production. In terms of crop production, boron toxicity is more difficult to manage than boron deficiency. Boron deficiency can be managed by appropriate boron fertilization. Searches for wheat and barley cultivars that tolerate high levels of boron have long been going on with moderate success. It may require a long term effort, but understanding at the molecular level of the boron transport/utilization mechanisms in plants may provide us with a novel strategy to improve crop plant for better nutrient transport properties that allows plants to withstand low and/or high boron stresses.

## Methods

### *Identification of boron transporters*

*Arabidopsis thaliana* was used for the identification of boron transporters. Two strategies are employed. One is so-called forward genetics. Mutants of *A. thaliana* with altered properties of boron transport/utilization have been screened. Identified mutants were subjected to genetic analysis and with the use of molecular markers, region of the chromosomes where the responsible genes are located are identified. Usually we analysed about 2,000 F2 plants and the regions of chromosomes are narrowed to less than 50 kB before determination of nucleotide sequences. Once the mutation was identified, alleles are obtained in many cases from the ABRC stock centre and used for confirmation of the mutation. Another approach is microarray analysis of the transcripts. RNAs were isolated from boron deficiency treated roots of *A. thaliana* and subjected to Affimetrix microarray analysis. Genes that are strongly induced by low boron treatment were identified and subjected to further molecular genetic and physiological analysis.

### *Physiological and molecular biological characterisations*

Detailed methods are described in our publications. In brief, growth of the mutant plants were analysed in many case on media with altered boron concentration (please see Noguchi *et al.* 1997 for details). Boron concentrations in plant tissues are determined with inductively coupled plasma-mass spectrometry. We have used reporter genes such as  $\beta$ -glucuronidase (GUS) and green fluorescent protein (GFP) for monitoring expression of genes in transgenic plants. Transformation of *A. thaliana* was done with the floral dip method and several independently transformed plants were analysed to confirm functions of introduced transgenes.

### **Results**

#### *BOR1, the first boron transporter identified in the living systems, for xylem loading of boron*

*A. thaliana bor1-1* mutant was identified as a low boron-sensitive mutant. In *bor1-1*, leaf expansion of upper leaves was inhibited when plants were grown with 3  $\mu$ M boric acid, while the wild type plants grew normally at this B concentration. Growth of the *bor1-1* plants was similar to the wild type when grown with 30  $\mu$ M boric acid (Noguchi *et al.* 1997). In *bor1-1* reduction of B concentration was evident in shoots compared to the roots, indicating that the *bor1-1* mutant is defective in B translocation from roots to shoots. Further physiological analysis revealed that the mutant is incapable of concentrating boric acid at the xylem-loading step (Takano *et al.* 2002). In addition to xylem loading, Takano (2001) demonstrated that *bor1-1* is defective in preferential B translocation into young leaves, this may be related to the function of NIP6;1 as described below (Tanaka *et al.* 2008).

Map-based cloning identified *BOR1* as At2g47160. *BOR1* has a high similarity to anion exchanger proteins, including the well-characterized Band3 protein in erythrocyte in animals. *BOR1* has putative ten transmembrane regions and GFP fusion protein was localized to the plasma membrane. *BOR1* has an efflux transport activity of boron in yeast cells (Takano *et al.* 2002). Taken together, *BOR1* is an efflux transporter of boron and required for xylem loading of boron from symplasts against concentration gradient. *BOR1*-like genes are also found in yeast and human and some of them are shown to be B transporters (Takano *et al.* 2007). In rice, it is demonstrated that *BOR1* is also important for boron transport. Interestingly rice *BOR1* not only functions in xylem loading of B, but also boron uptake into roots (Nakagawa *et al.* 2007). This may be a reflection of different root structures and different cell-specificity of expression.

It is known that expression of nutrient transporters are regulated in response to the availability of substrate. In the case of *BOR1*, mRNA was not significantly changed under various B conditions, however, accumulation of *BOR1* protein decreased under high B supply both in roots and shoots (Takano *et al.* 2005). Cell biological analysis including inhibitors of membrane trafficking revealed that *BOR1* degradation in response to high boron supply is via endocytosis (Takano *et al.* 2005). This was the first example of an endocytosis-mediated degradation of a plasma membrane protein in plants. This degradation is probably important to avoid high accumulation of boron in shoots under conditions of high boron supply to avoid toxicity symptoms in leaves.

#### *BOR4 for boron exclusion from roots*

Six *BOR1* paralogs (*BOR2*-*BOR7*) are present in the *A. thaliana* genome. We examined transport activities of these paralogs and all were capable of reducing boron concentration in yeast cells. Accumulation of mRNAs corresponding to *BOR2*, *BOR3*, *BOR4* and *BOR5* was detected by RT-PCR both in shoots and roots of plants at vegetative stages. *BOR6* and *BOR7* transcripts were detected only in flowers. Genetic analysis revealed that *BOR2* and *BOR3* are important for normal growth under low B condition. *BOR4* was found to be involved in high boron tolerance by excluding boric acid out of root cells. *BOR4* is an active efflux transporter of boron and is localized in the outer side of the epidermal plasma membrane (Miwa *et al.* 2007).

#### *NIP5;1 for boron uptake into roots*

A gene was identified as a low-B inducible gene through the microarray analysis. RNAs were isolated from wild type *A. thaliana* roots treated with normal or low B for 3 days and microarray analysis identified *NIP5;1* as a low-B inducible gene. GFP-*NIP5;1* fusion protein was localized to the plasma membrane in *A. thaliana* protoplasts. *NIP5;1* allowed high uptake of B into *Xenopus* oocytes, suggesting that *NIP5;1* is a channel for boric acid. The two independent T-DNA insertion lines *nip5;1-1* and *nip5;1-2* showed severe growth reduction both in shoots and in root cell elongation only under limited supply of B, and both grew normally under normal B conditions. Amounts of B uptake into roots were increased in wild type plants

under low B supply compared to those under high B supply, whereas this increase of B uptake was not observed in the *nip5;1-1* mutant. These observations demonstrated that NIP5;1 is essential for B uptake into root cells to support normal plant growth under B limitation. Given the similarity to aquaporins, NIP5;1 is likely to transport boric acid according to concentration gradient, and to contribute to satisfy B requirement in shoot and root growth.

#### *NIP6;1 for preferential distribution of boron to young portions of shoot*

We investigated the function of *NIP6;1*, the most similar gene to *NIP5;1*, through reverse genetic approach. *NIP6;1* facilitates permeation of boric acid across the membrane when expressed in *Xenopus* oocytes, but is completely impermeable to water. *NIP6;1* transcript accumulation is elevated in response to B deprivation in shoots, but not in roots. *NIP6;1* promoter-GUS (Tanaka *et al.* 2008) is predominantly expressed in nodal regions of shoots, especially the phloem region of vascular tissues. Three independently identified T-DNA insertion lines for the *NIP6;1* gene exhibited reduced expansion of young rosette leaves only under low B conditions. B concentrations decreased in young rosette leaves but not in the old leaves of these mutants. These results strongly suggest that *NIP6;1* is a boric acid channel required for proper distribution of boric acid particularly to young developing shoot tissues. *NIP6;1* is likely to be involved in xylem-phloem transfer of boric acid at the nodal regions. The water-tight property of *NIP6;1* may be important for the boric acid transfer without disturbing transport processes in phloem.

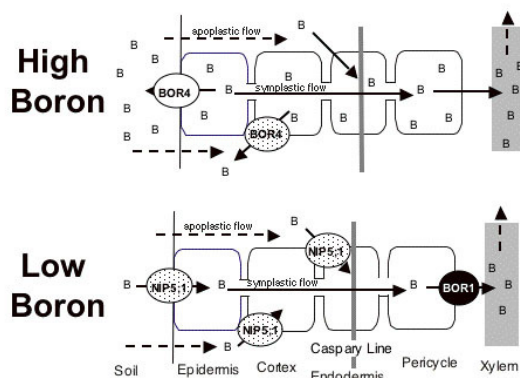

**Figure 1. A model of boron transport across root cells in *Arabidopsis thaliana*. Under low boron conditions, NIP5;1 and BOR1 coordinately drives efficient boron transport across roots into xylem. Under high boron conditions, NIP5;1 is not strongly expressed and BOR1 degraded. Instead, BOR4 is accumulated to drive efflux of boron from symplast to soil solution to reduce concentration of toxic boron in roots. Role of NIP6;1 is mostly in shoots.**

#### *Generation of plants tolerant to boron stresses through enhancement of boron transporter activities*

Based on our understanding of molecular mechanism of boron transport in plants, we successfully generated plants that withstand in low and/or high boron conditions. The first trial was to overexpress BOR1. We generated transgenic *A. thaliana* lines expressing BOR1 under the control of CaMV 35S RNA promoter. The transgenic plants showed significant improvement of shoot growth and fertility under limited supply of B (Miwa *et al.* 2006). It was found that the boron loading in xylem was elevated in the transgenic lines and this is likely to be the reason for the enhanced growth under conditions of limited boron supply. It is likely that function of endogenous BOR1 as a xylem loader of B was enhanced in these transgenic lines. The advantage of this approach is that there is no detrimental effect on plant growth under normal or toxic level of B supply, probably due to the degradation of BOR1 under high B conditions (Takano *et al.* 2005).

In the course of the study we noticed that overexpression of B transporter BOR1 improves shoot growth, but not root growth under low B. This is reasonable as BOR1 is a transporter for xylem loading. We examined if overexpression of *NIP5;1* may improve root growth under low B conditions. We first generated transgenic plants overexpressing *NIP5;1*, but the growth of transgenic plants are not improved rather impaired. We then tried not overexpression but enhancement of *NIP5;1* expression by inserting enhancer element upstream of the promoter of *NIP5;1*. The plants with enhanced expression of *NIP5;1* exhibited improved root elongation under low B conditions (Kato *et al.* 2009). Overexpression of *BOR1* in the *NIP5;1* activation tag line resulted in plants with high tolerance to low B.

These represent the first successful improvement of boron deficiency tolerance through modification of transporters. This also reveals potentials of enhancing expression of a mineral nutrient channel gene to improve growth under nutrient limiting conditions. We also succeeded in generating plants with high boron tolerance (Miwa *et al.* 2007). B toxicity is often problem in agricultures in semi arid areas. We constructed transgenic *A. thaliana* lines overexpressing BOR4, a paralog of BOR1. BOR4 accumulation was enhanced when the boron concentration in the media is high. This is a sharp contrast to the case of BOR1. BOR1 diminishes under high B conditions. The transgenic lines overexpressing BOR4 showed remarkable improvement of root and shoot growth under 10 mM B conditions, at this concentration of B the wild type plants fails to grow right after germination. B concentrations in roots and shoots were decreased in these transgenic plant lines. It is likely that overexpressed BOR4 pumps excess boron out of the cell (Miwa *et al.* 2007).

## Conclusion

Through the molecular genetic and physiological analysis, boron transporters were identified and their coordinated roles in boron transport from soil to roots and distribution within the plant body are unveiled. By enhancing the activities of appropriate transporters, it is now possible to generate plants tolerant to low or high boron conditions.

## References

- Kato Y, Miwa K, Takano J, Wada M, Fujiwara T (2009) Highly boron deficiency-tolerant plants generated by enhanced expression of NIP5;1, a boric acid channel. *Plant Cell Physiol.* **50**, 58-66.
- Miwa K, Kamiya T, Fujiwara T (2009) Homeostasis of the structurally important micronutrients, B and Si. *Curr Opin Plant Biol* **12**, 307-311.
- Miwa K, Takano J, Omori H, Seki M, Shonozaki K, Fujiwara T (2007) Plants tolerant of high boron levels. *Science* **318**, 1417.
- Miwa K, Takano J, Fujiwara T (2006) Improvement of seed yields under boron-limiting conditions through overexpression of BOR1, a boron transporter for xylem loading, in *Arabidopsis thaliana* *Plant J* **46**, 1084-1091.
- Nakagawa Y, Hanaoka H, Kobayashi M, Miyoshi K, Miwa K, Fujiwara T (2007) Cell-type specificity of the expression of Os BOR1, a rice efflux boron transporter gene, is regulated in response to boron availability for efficient boron uptake and xylem loading. *Plant Cell* **19**, 2624-2635.
- Noguchi K, Yasumori M, Imai T, Naito S, Matsunaga T, Oda H, Hayashi H, Chino M, Fujiwara (1997) bor1-1, an Arabidopsis thaliana mutant that requires a high level of boron. *Plant Physiol.* **115**, 901-906.
- Takano J, Kobayashi M, Noda Y, Fujiwara T (2007) *Saccharomyces cerevisiae* BOR1p is a boron exporter and a key determinant of boron tolerance. *FEMS Microbiol. Lett.* **267**, 230-235.
- Takano J, Miwa K, Fujiwara T (2008) Boron transport mechanisms: collaboration of channels and transporters. *Trends Plant Sci* **13**, 451-457.
- Takano J, Wada M, Ludewig U, Schaaf G, von Wiren, Fujiwara T (2006) The Arabidopsis major intrinsic protein NIP5;1 is essential for efficient boron uptake and plant development under boron limitation. *Plant Cell* **18**, 1498-1509.
- Takano J, Miwa K, Yuan L, von Wire n N, Fujiwara T (2005) Endocytosis and degradation of BOR1, a boron transporter of Arabidopsis thaliana, regulated by boron availability. *Proc. Natl. Acad. Sci. USA* **102**, 12276-12281.
- Takano J, Noguchi K, Yasumori M, Kobayashi M, Gajdos Z, Miwa K, Hayashi H, Yoneyama T, Fujiwara T (2002) Arabidopsis boron transporter for xylem loading. *Nature* **420**, 337-340.
- Takano J, Yamagami M, Noguchi K, Hayashi H, Fujiwara T (2001) Preferential translocation of boron to young leaves in *Arabidopsis thaliana* regulated by the BOR1 gene. *Soil Sci. Plant Nutr* **47**, 345-357.
- Tanaka M, Wallace I, Takano J, Roberts RM, Fujiwara T (2008) NIP6;1 is a boric acid channel for preferential transport of boron to growing shoot tissues in *Arabidopsis thaliana*. *Plant Cell* **20**, 2860-2875.